



厦门友盟电子有限公司

XIAMEN UME ELECTRONICS CO., LTD.

产品规格承认书 SPECIFICATION

文件编号 File No.: UME-EG-SP20111301/A1

客户 Customer	AKON	核准 Approval	JB
品名 Product	开关电源 Switching power supply	品管确认 QC	TF
型号 Model	AD-AKB120P200	审核 Check	ZL
日期 Date	2021-1-26	拟制 Execution	BMD

客户承认意见 Confirmation by Customer	客户签署 Stamp & Signature
<input type="checkbox"/> 合格 Accept	
<input type="checkbox"/> 不合格 Reject	
<input type="checkbox"/> 条件合格 Conditional Acceptance	

确认签署后，请回传一份。有任何问题，请尽快告知我们。

Please return one copy to us with your signature and feel free to contact us for any questions.

厦门友盟电子有限公司

XIAMEN UME ELECTRONICS CO., LTD.

电话 Tel:0592-2611448

传真 Fax:0592-5755330

地址:厦门湖里区殿前一路536号

Add:NO. 536 Dianqian YiLu, Huli District, Xiamen.



产品规格承认书 SPECIFICATION				文件编号 File No.	UME-EG-SP20111301/A1
品名 Product	开关电源 SPS	型号 Model	AD-AKB120P200	日期 Date	2021-1-26

目录 INDEX

1	变更履历 Revision History	1-3
2	概述 Summary	2-4
3	技术要求 Technical requirements.....	3-4
3.1	安全标准 Safety Standards	3-4
3.2	Input.....	3-4
3.3	Output.....	3-4
3.4	可靠性及质量控制 Reliability and Quality Control	3-5
3.5	测试线路图 Test Circuit.....	3-9
4	线路图 Schematic Diagram	4-9
5	电路板图 P.C.B.....	5-10
6	Cord (单位 unit: mm 颜色 color: BK)	6-11
7	外观示意图 Mechanical Drawing (单位 unit: mm 颜色 color: BK)	7-12
8	铭板标识 Label.....	8-13
9	包装方式 Packaging	9-13
10	材料清单 BOM	10-14

*** The products limited warranty period is 18 months.
(From date code of product.)**

*** The products meet RoHS requirements.**

批准 Approval:	<i>JB</i>	审核 Check:	<i>ZL</i>	制表 Execution:	<i>BMD</i>
-----------------	-----------	-----------	-----------	---------------	------------



产品规格承认书 SPECIFICATION				文件编号 File No.	UME-EG-SP20111301/A1
品名 Product	开关电源 SPS	型号 Model	AD-AKB120P200	日期 Date	2021-1-26

2 概述 Summary

2.1 本文件包含一般的客户要求及电气、机构和安全性能等方面的描述。

This document contains general customer requirements and those of specific electrical, mechanical and safety for this product.

3 技术要求 Technical requirements

3.1 安全标准 Safety Standards

Japan: 電安法別表第八【JET6108-61010-1007】

3.2 Input

Rated Input Voltage	100-240Vac
Operating Range	90-264Vac
Rated Input Frequency	50/60Hz
Rated Input Current	0.6A
Maximum Input Power	29W
Input Power (No Load)	0.1W Max
Primary Current Protection	Over current protection: Current fuse

3.3 Output

Rated Dc Output Voltage	12V ± 5%
Rated Load Current	2000mA
过流保护 Over Current Protection	The power supply will be protection when output power over 110% ~ 150% of all rated DC output.
Over Voltage Protection	18V Max at Vin 100Vac/240Vac
Line Regulation	The line regulation is less than ±2% while measuring at rated load and +/-5% of input voltage changing.
Ripple	≦ 120mVp-p
Switching Efficiency	86.20% minimum @ input 115AC/230VAC to meet DOE6
DC Plug	Φ2.1*5.5*9.5mm
DC Cord	20AWG 2464 L = 1500mm, Black Lead-free soldering

批准 Approval:	<i>JB</i>	审核 Check:	<i>ZL</i>	制表 Execution:	<i>BMD</i>
-----------------	-----------	-----------	-----------	---------------	------------



产品规格承认书 SPECIFICATION				文件编号 File No.	UME-EG-SP20111301/A1
品名 Product	开关电源 SPS	型号 Model	AD-AKB120P200	日期 Date	2021-1-26

3.4 可靠性及质量控制 Reliability and Quality Control

【Electrical Test Items】

Item	Conditions	Criteria
1	Leakage Current Measure the leakage current between Primary and Secondary when adding rated input. AC input = Rating voltage (100/240V)	Less than 250 μ A
2	ESD Test 1.Test is conducted at room temperature/ humidity.(25 $^{\circ}$ C, RH 50-60%) 2.Test set is 150pF/150 Ω . 3.(1) \pm 4KV:Contact discharge test. +phase: 3times, -phase: 3times, total: 6times. (2) \pm 8KV:Air discharge test. +phase : 3times, -phase: 3times, total: 6times. (Note) After each ESD test, it should be discharged.	No malfunction (must be in spec after test).
	1.Test is conducted at room temperature/humidity.(25 $^{\circ}$ C, RH 50-60%) 2.Test set is 150pF/150 Ω . 3.(1) \pm 6KV:Contact discharge test. + phase: 3times, -phase: 3times total: 6times. (2) \pm 10KV:Air discharge test. + phase: 3times, -phase: 3times, total: 6times. (Note)After each ESD test, it should be discharged.	No destruction
	ESD Test (Ability test) 1.Test is conducted at room temperature/humidity.(25 $^{\circ}$ C, RH 50-60%) 2.Test condition: 150pF/150 Ω . 3,Contact discharge / Air discharge 4,Load: 1)no load 2)rated load 5. Impressing 10 times continuously to plus and minus each. 6,Discharging once after impressing 10 times (To confirm the capacity of unit up to the unit destroyed)	It confirms at which voltage value the adapter breaks.(Note: Not part of qualification)
3	Hi-POT test Condition=AC3000V, 1min. Test place=Between AC blade and DC plug Sensitivity current=10mA	No malfunction. (damage, arc, breakdown etc)
4	Insulation resistance DC500V, 1min. Between AC blade and DC plug	More than 100M Ω
5	Temperature Rise Test 1.Apply rating input voltage(100/240V), 2.Load: Charge actual Cellular phone 3.Measure the surface temperature of the adaptor 4.T ambient = The room temperature 5.Condition: Until it carries out temperature saturation (the definition of temperature than 1 $^{\circ}$ C in 1 hour).	Housing surface Temperature rise is less than 45K.

批准 Approval:	<i>JB</i>	审核 Check:	<i>ZL</i>	制表 Execution:	<i>BMD</i>
-----------------	-----------	-----------	-----------	---------------	------------



产品规格承认书 SPECIFICATION				文件编号 File No.	UME-EG-SP20111301/A1
品名 Product	开关电源 SPS	型号 Model	AD-AKB120P200	日期 Date	2021-1-26

		1.Apply rating input voltage(100/240V), 2.No Load 3.Measure the surface temperature of the adaptor	Housing surface Temperature rise is less than 15K.
6	Input over / under	Apply voltage=(rating input voltage)x(1±30%) Impressed time : 24h	No destruction
7	EMI/Conducted Emission	Telephone stand by mode with rapid-charge condition	Conform to: FCC 47CFR Part 15 Class B (for US) EN55022 (For Japan)
8	Surge	IEC61000-4-5 1.2×50µs 1.0KV Positive and negative all three times, Current limiting impedance 100 Ω, Time interval 30 seconds min.	No destruction.

【Environmental Test Items】

Item		Conditions	Criteria
1	Temperature range	Electrical performance guarantees temperature range: 0°C to 40°C Electrical performance not guarantees working temperature range: -20°C to 50°C Storage temperature range: -30°C to 80°C	
2	High Temperature Leave	1. Temperature 80°C for 96 hours. 2. After that test, test set is left in normal temperature, humidity condition for more than 1hour, then evaluate.	No abnormal appearance, mechanic performance or electric performance
3	Low Temperature Leave	1. Temperature -30°C for 96 hours. 2. After that test, test set is left in normal temperature, humidity condition more than 1(hour), then evaluate.	
4	High Temperature Humidity	1. Temperature 50°C, air moisture 90-95% RH for 96 hours. 2. After that test, test set is left in normal temperature, humidity condition more than 30min, then evaluate.	
5	Temperature Humidity test	1. Temperature 40°C, air moisture 90-95% RH for 96 hours. 2. After that test, test set is left in normal temperature, humidity condition more than 30min, then evaluate.	
6	Heat Shock Test	1. Condition: -30°C/ 1 hour to +80°C/ 1 hour, 60 cycles 2. After that test, test set is left in normal temperature, humidity condition more than 1 hour, then evaluate.	

批准 Approval:	JB	审核 Check:	ZL	制表 Execution:	BMD
-----------------	----	-----------	----	---------------	-----



产品规格承认书 SPECIFICATION				文件编号 File No.	UME-EG-SP20111301/A1
品名 Product	开关电源 SPS	型号 Model	AD-AKB120P200	日期 Date	2021-1-26

7	Heat/humidity Cycle Test	<p>A, C, D : RH=90 ± 10% B : RH= 90 ± 5% E : No limit After 5cycles, put EUT at room temperature/humidity condition</p> <p style="text-align: center;"> +70°C +70°C +45°C +45°C 室温or +20°C 室温or +20°C -20°C -20°C </p> <p style="text-align: center;"> 2h 4h 2h 12h 1h 2h 1h </p>	
---	-----------------------------	--	--

【Mechanical Test Items】

Item	Conditions	Criteria
1	Drop Test	Height of drop: 1m, 1times/each surface (total 6 times), Floor: Hardwood.
2	Package Drop Test	1. Packaged condition. 2. Drop test points (1) 1 corner (2) 2 edges (3) 4 surfaces, Total: 7times drop test. 3. Height of drop:50cm. Bottom surface drop test only apply 65cm.
3	Unit Vibration Test	1. Vibration condition:33.3Hz/min. 20.6m/s ² 2. (1)Top/Bottom direction:4-hours (2)Right/Left direction:2-hours (3) Front/Back direction:2-hours
4	Package Vibration	1.Vibration condition: 5-55-5Hz/2min. (1)Top/Bottom direction : 12.5(m/S ²)30(min) (2) Right/left direction : 7.5(m/S ²)15(min)*2
5	AC Plug in/out Test (AC Blade part)	1. AC Plug in/out test more than 5000times 2.10(times/min). 1 time is in/out action.
6	Exfoliate with cellophane tape and examine it	Use Nichiban 18mm or 24mm width A character do not disappear.
7	The reliability to face each other to come off the label	① -40°C ② 80°C ③ 50°C 90% Each 96 hours ④ ③ After, it is a thermal shock examination of 96 cycles Don't take the label off the main body

批准 Approval:	JB	审核 Check:	ZL	制表 Execution:	BMD
-----------------	----	-----------	----	---------------	-----



产品规格承认书 SPECIFICATION				文件编号 File No.	UME-EG-SP20111301/A1
品名 Product	开关电源 SPS	型号 Model	AD-AKB120P200	日期 Date	2021-1-26

8	No tally part step	Difference of the pitch by height differences of the tally part between casts	less than 0.25mm after an environmental examination
---	--------------------	---	---

【DC cord Test Items】

Item	Conditions	Criteria
1 DC Cord strength (adaptor side / plug side)	1. Test part: Between adaptor and DC cord 2. Pull a cord with 98N(10Kgf) force 3. Time: 1min.	No abnormality such as wire cut, bushing come off
2 DC Cord Bending Test (adaptor side / plug side)	Weight = 4.9N(500g) Angle = +/-90° Cycles in every minute = 40times/min. Test cycles = 1000times Note: contrarotate 90°, and then rotate it clockwise with 180°(+90°~-90°), and at last return to origin. (1 Cycle : 0°⇒-90°⇒0°⇒+90°⇒0°)	Operate properly.

【Safety Test Items】

1	MTBF	Make a measurement condition, a calculation standard clear	More than 50,000 hours
2	Part materials	It is maintenance or the incombustibility of contact / part materials approaching it in an outer fence, the charge department of the electric part	same as UL94V-0; more than it
3	print board	Incombustibility	same as UL94V-0; more than it
4	No tally part step	Difference of the pitch by height differences of the tally part between casts	less than 0.25mm after an environmental examination

批准 Approval:	JB	审核 Check:	ZL	制表 Execution:	BMD
-----------------	----	-----------	----	---------------	-----



产品规格承认书 SPECIFICATION				文件编号 File No.	UME-EG-SP20111301/A1
品名 Product	开关电源 SPS	型号 Model	AD-AKB120P200	日期 Date	2021-1-26

3.5 测试线路图 Test Circuit

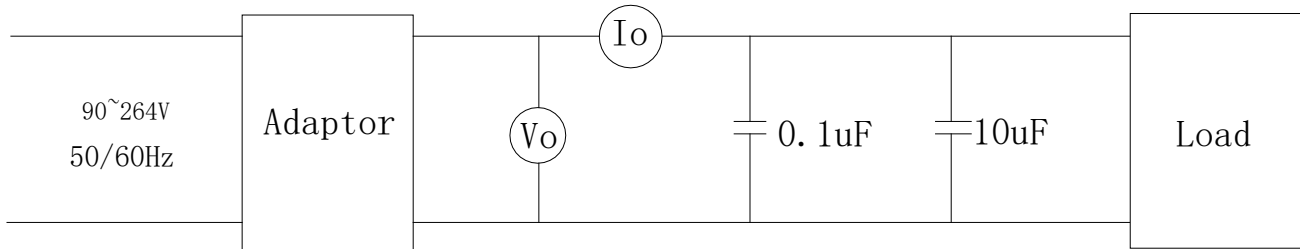

4 线路图 Schematic Diagram

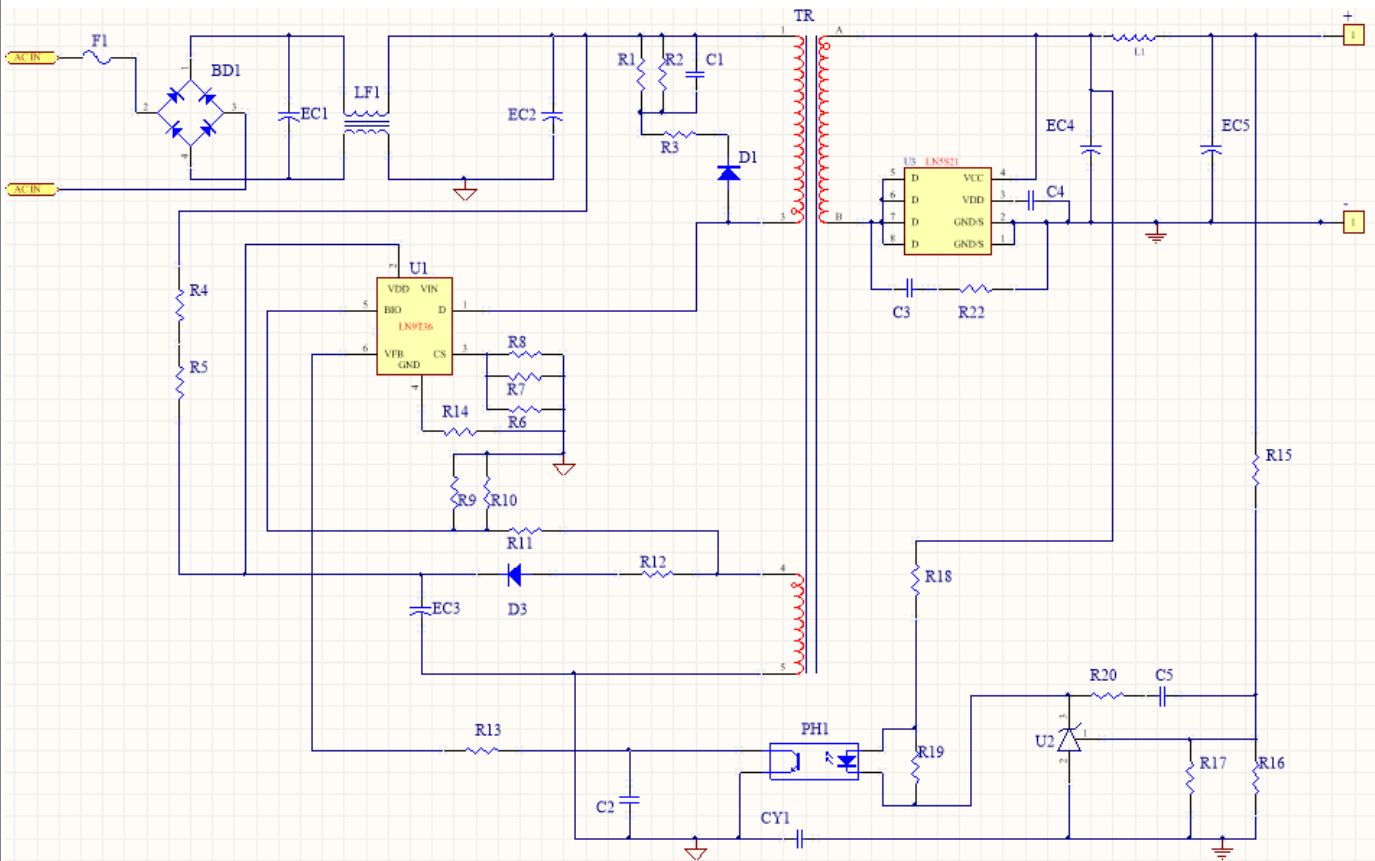

批准 Approval:	JB	审核 Check:	ZL	制表 Execution:	BMD
-----------------	----	-----------	----	---------------	-----



产品规格承认书 SPECIFICATION			文件编号 File No.	UME-EG-SP20111301/A1	
品名 Product	开关电源 SPS	型号 Model	AD-AKB120P200	日期 Date	2021-1-26

5 电路板图 P.C.B

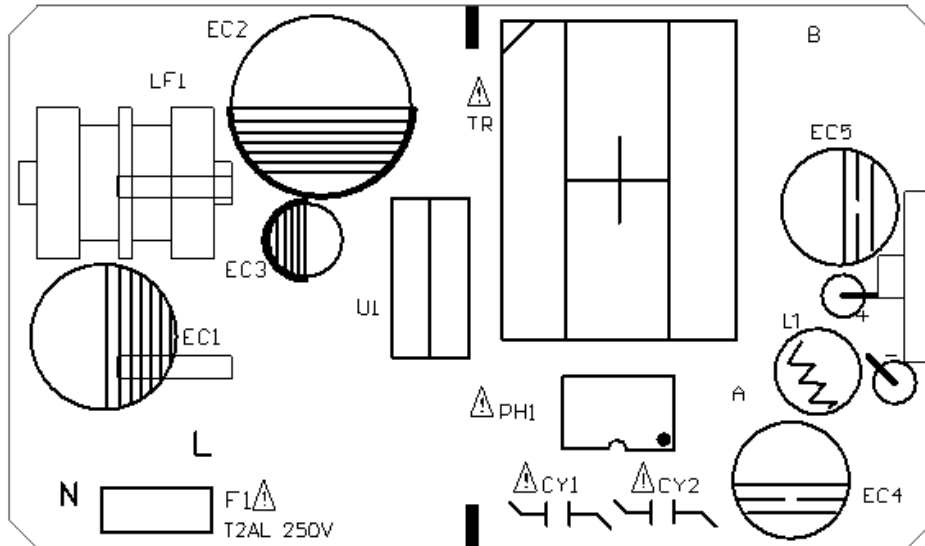
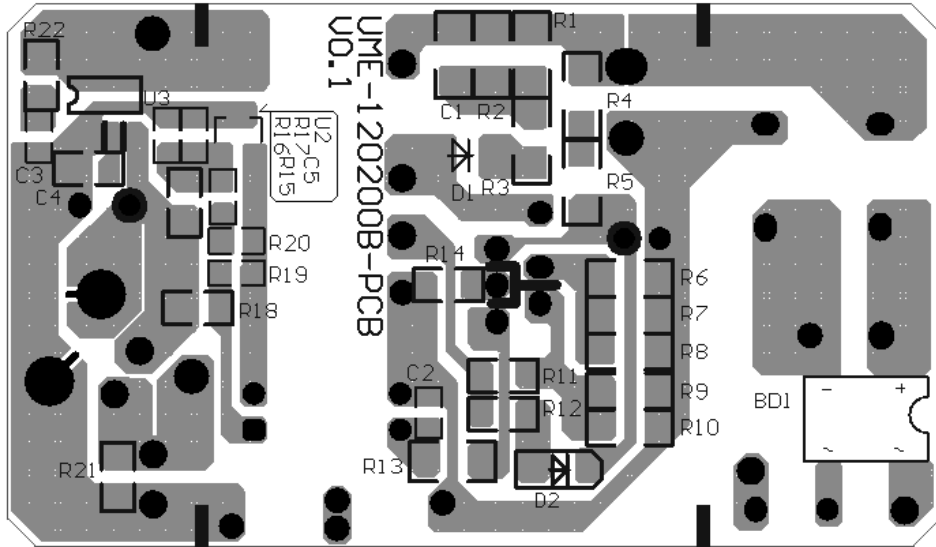

批准 Approval:	JB	审核 Check:	ZL	制表 Execution:	BMD
-----------------	----	-----------	----	---------------	-----



产品规格承认书 SPECIFICATION			文件编号 File No.	UME-EG-SP20111301/A1	
品名 Product	开关电源 SPS	型号 Model	AD-AKB120P200	日期 Date	2021-1-26

6 Cord (单位 unit: mm 颜色 color: BK)

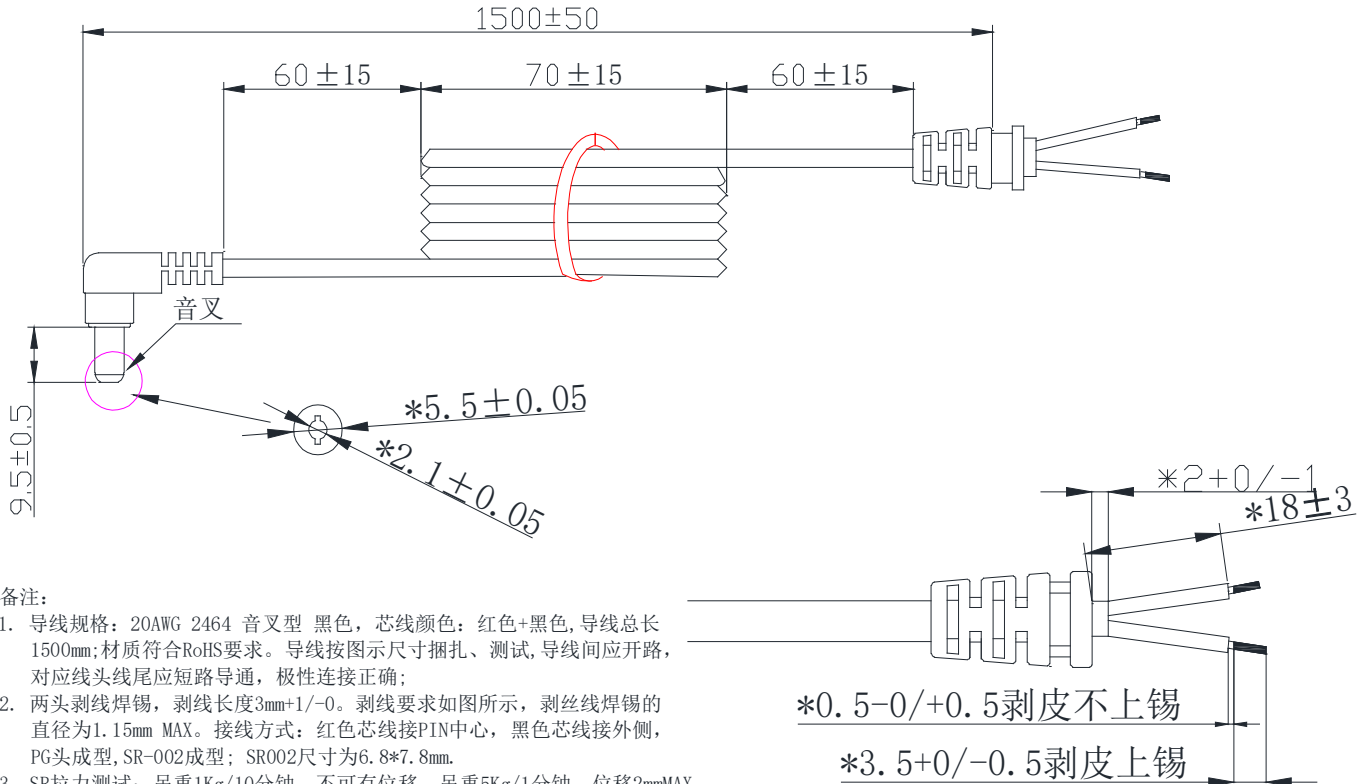

备注:

1. 导线规格: 20AWG 2464 音叉型 黑色, 芯线颜色: 红色+黑色, 导线总长 1500mm; 材质符合RoHS要求。导线按图示尺寸捆扎、测试, 导线间应开路, 对应线头线尾应短路导通, 极性连接正确;
2. 两头剥线焊锡, 剥线长度3mm+1/-0。剥线要求如图所示, 剥丝线焊锡的直径为1.15mm MAX。接线方式: 红色芯线接PIN中心, 黑色芯线接外侧, PG头成型, SR-002成型; SR002尺寸为6.8*7.8mm。
3. SR拉力测试: 吊重1Kg/10分钟, 不可有位移, 吊重5Kg/1分钟, 位移2mmMAX
4. 插拔力测试: 插入力2KgMAX, 拔出力0.3KgMIN; 插拔6000MIN次不允许有电气和机械性能的损坏, 且满足拔出力0.1KgMIN;
5. 摇摆测试: 吊重500g, 以40次/分作90°往返, 每一往返为一次, 至少1000次;
6. PLUG绝缘阻抗测试: 100MΩ MIN在500DC/分; PLUG接触阻抗测试: 100mΩ MAX;
7. 导线, SR, PLUG非移行性依据厂内一般进行; 禁止使用VDE所禁用的物质。
8. 打*号尺寸, 为入料检查项目;

批准 Approval:	JB	审核 Check:	ZL	制表 Execution:	BMD
-----------------	----	-----------	----	---------------	-----



产品规格承认书 SPECIFICATION				文件编号 File No.	UME-EG-SP20111301/A1
品名 Product	开关电源 SPS	型号 Model	AD-AKB120P200	日期 Date	2021-1-26

7 外观示意图 Mechanical Drawing (单位 unit: mm 颜色 color: BK)

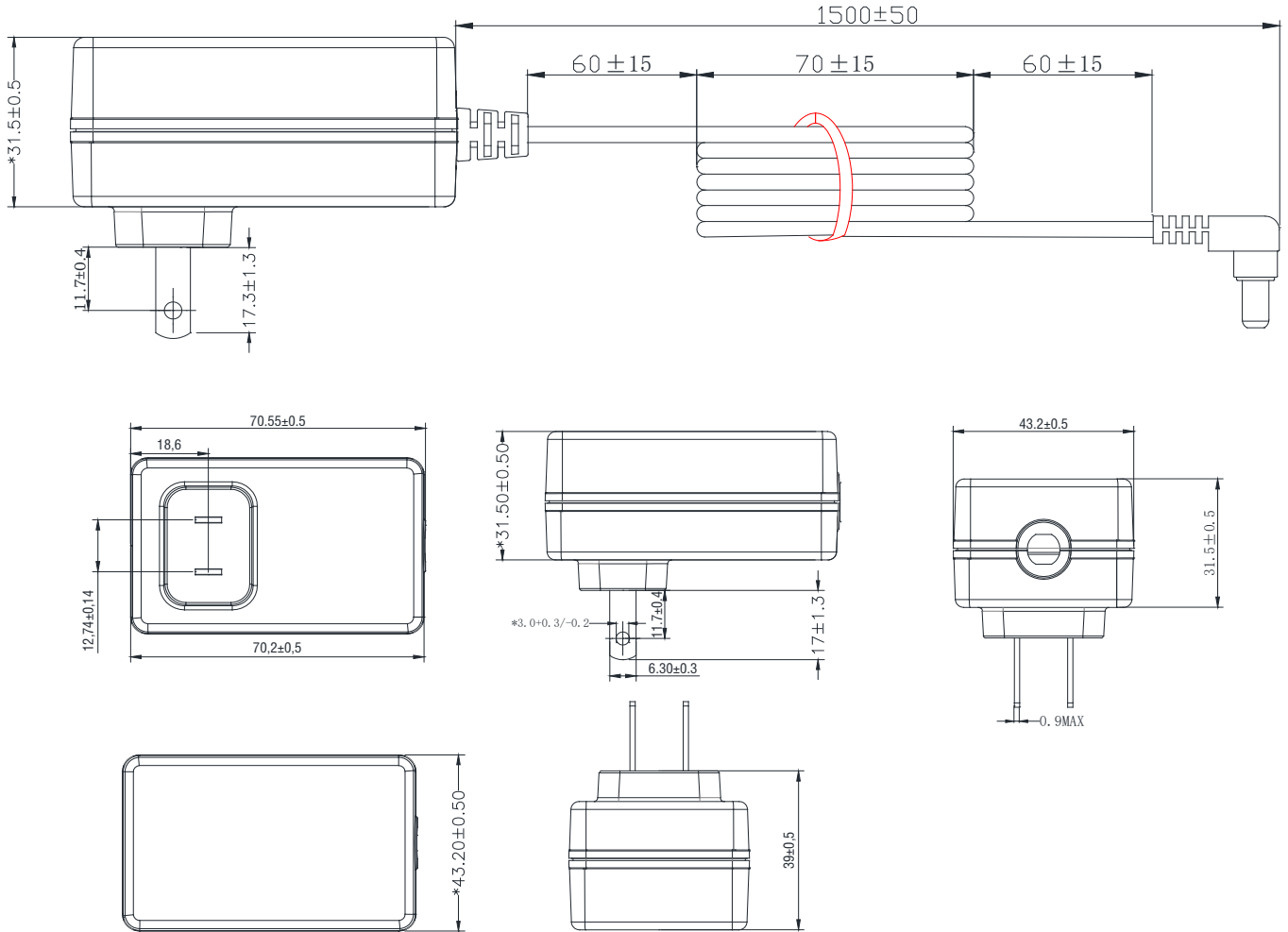

批准 Approval:	JB	审核 Check:	ZL	制表 Execution:	BMD
-----------------	----	-----------	----	---------------	-----



产品规格承认书 SPECIFICATION				文件编号 File No.	UME-EG-SP20111301/A1
品名 Product	开关电源 SPS	型号 Model	AD-AKB120P200	日期 Date	2021-1-26

8 铭板标识 Label

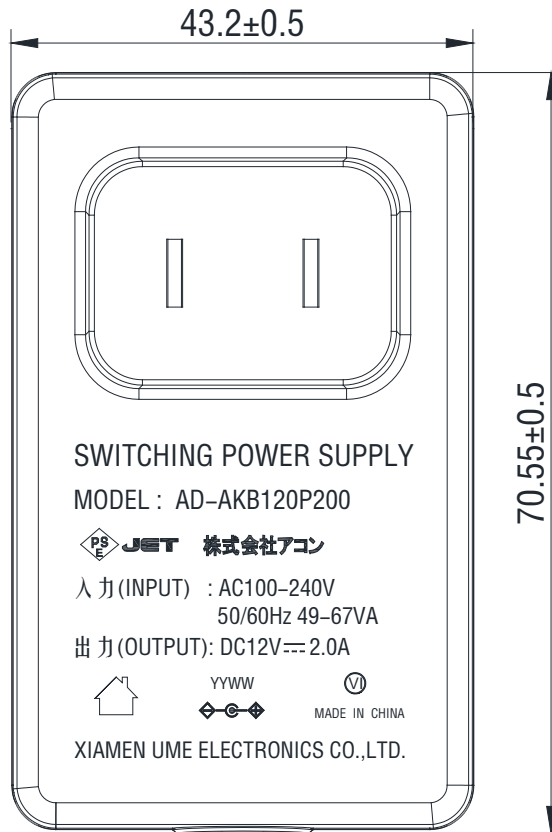

9 包装方式 Packaging

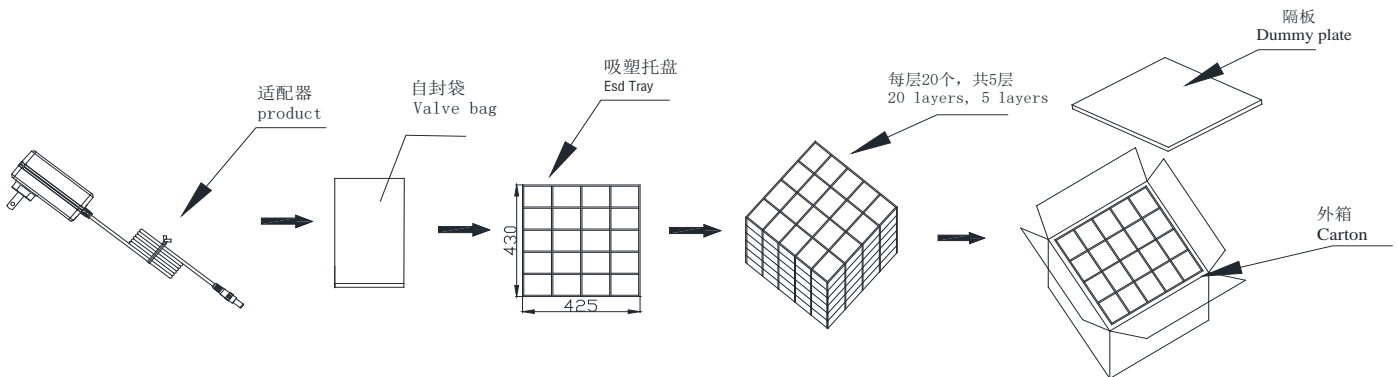

批准 Approval:	JB	审核 Check:	ZL	制表 Execution:	BMD
-----------------	----	-----------	----	---------------	-----



产品规格承认书 SPECIFICATION				文件编号 File No.	UME-EG-SP20111301/A1
品名 Product	开关电源 SPS	型号 Model	AD-AKB120P200	日期 Date	2021-1-26

10 BOM list

NO.	ITEM	DESCRIPTION	SPECIFICATION	QTY	MANUFACTURER
1	PCB	PCB	UME-120200B-PCB	1	TengShengXing/HG
2	R1, R2	CHIP R	300K Ω ±5% 1206	2	YAGEO/FENG HUA
3	R3	CHIP R	300 Ω ±5% 1206	1	YAGEO/FENG HUA
4	R5, R4	CHIP R	1.5M Ω ±5% 1206	2	YAGEO/FENG HUA
5	R6, R7	CHIP R	2.4 Ω ±1% 1206	2	YAGEO/FENG HUA
6	R8	CHIP R	2.7 Ω ±1% 1206	1	YAGEO/FENG HUA
7	R9	CHIP R	20K Ω ±5% 1206	1	YAGEO/FENG HUA
8	R10,R11	CHIP R	100K Ω ±5% 1206	2	YAGEO/FENG HUA
9	R12	CHIP R	4.7 Ω ±5%1206	1	YAGEO/FENG HUA
10	R13, R14	CHIP R	0 Ω ±5% 1206	2	YAGEO/FENG HUA
11	R15	CHIP R	20K Ω ±1% 1206	1	YAGEO/FENG HUA
12	R16	CHIP R	5.1K Ω ±1% 0805	1	YAGEO/FENG HUA
13	R18	CHIP R	510 Ω ±5% 0805	1	YAGEO/FENG HUA
14	R19,R20	CHIP R	1K Ω ±5% 0805	2	YAGEO/FENG HUA
15	R22	CHIP R	10 Ω ±5% 0805	1	YAGEO/FENG HUA
16	C1	CHIP C	102 500±10% 1206 X7R	1	YAGEO/FENG HUA
		CHIP C	102 630±10% 1206 X7R		YAGEO/FENG HUA
17	C2	CHIP C	222 50V±10% 0805 X7R	1	YAGEO/FENG HUA
18	C3	CHIP C	222 100V±10%0805 X7R	1	YAGEO/FENG HUA
19	C4	CHIP C	105 16±10% 0805 X7R	1	YAGEO/FENG HUA
20	C5	CHIP C	224 50V±10% 0805 X7R	1	YAGEO/FENG HUA
21	BD1	Rectifier Bridge	DB106S 800V 1A	1	JF/ World
22	D1	Diode	M7 SMA	1	JF/MIC/PANJIT
23	D2	Diode	F7 1A/1000V/SOD-123FL	1	ZW/JF
24	U2	IC	CJ431±0.5% SOT-23	1	Changdian/UTC
25	U3	IC	LN5S21A SO-8C	1	LSM

批准 Approval:	<i>JB</i>	审核 Check:	<i>ZL</i>	制表 Execution:	<i>BMD</i>
-----------------	-----------	-----------	-----------	---------------	------------



产品规格承认书 SPECIFICATION				文件编号 File No.	UME-EG-SP20111301/A1
品名 Product	开关电源 SPS	型号 Model	AD-AKB120P200	日期 Date	2021-1-26

26	U1	IC	LN9T36 TSIP7	1	LSM
27	LF1	Inductor	18mH MIN UU9.8 180℃	1	HXH/CS
28	L1	Inductor	R3*15 3.3uH Φ0.5mm	1	HXH/CS
29	PH1	Photo	BPC-817MB DIP-4 P=10.2	1	Bright Led
			EL-817MB DIP-4 P=10.2		Everlight
30	CY1, CY2	Y Cap	Y2 222 250V±20% P=7.5mm	2	STE/HJ
31		Insulating strip	PET 0.25*33*36.5mm	1	YIHANGXING
32	TR1	TRANSFMOR	TR-120200C	1	HM/ HXH
33	EC1	E cap	18uF 400V±20% 105℃ Φ10×20mm(BXW)	1	RUBYCON
34	EC2	E cap	27uF 400V±20% 105℃ Φ12.5*20mm(BXF)	1	RUBYCON
35		E cap	27uF 400V±20% 105℃ Φ12.5*20mm(BXW)		RUBYCON
36	EC3	E cap	4.7uF 50V±20% 105℃ Φ5*11mm(YXF)	1	RUBYCON
37	EC4, EC5	E cap	680uF 16V±20% 105℃ Φ8*16mm(ZLH)	2	RUBYCON
38	F1	Fuse	5TE T2A/250V	1	XC/SET/Little fuse
39	L, N	Lead wire	UL 1007 24AWG 50mm	2	xinchengda
41	CASE	CASE	UMEC03A(BK)	1	JLF/YGE
42	CASE	CASE	UMEC03B(BK)	1	JLF/YGE
43	BLD1, BLD2	Blade	1.5*6.3*24.4	2	GuanQiao
44	DC cord	Cable	Φ2.1*5.5*9.5mm L:1500mm 20AWG 2464 BK	1	DPK/YC/Kaibo
45		Valve bag	160*120*0.02	1	Xincheng
46		Out carton	440*430*220mm BIN-090200C	0.01	Fuxing/Xinruicheng
47		Partition	435*418*3mm	0.01	Fuxing/Xinruicheng
48		Esd Tray	430*425*55mm	0.05	Fuxing/Xinruicheng
49		UL	UL UB-100	0.55	U-Bond
50		Solder Bar	1Cu 99Sn	0.4	Yun Nan TIN
51		Solder wire	0.3Ag 0.7Cu 99Sn	0.2	Yun Nan TIN

批准 Approval:	<i>JB</i>	审核 Check:	<i>ZL</i>	制表 Execution:	<i>BMD</i>
-----------------	-----------	-----------	-----------	---------------	------------