



Specification for Approval

Customer : 株式会社アコン

Part Name : AC ADAPTER (Open Frame)

Description : 24.0 Volts / 0.23 Amps

Model No. : ATS005A2-F240P (Level VI)

Customer P / N :

Product P / N : ATS005A2F240P000002

Issued Date : 12 - Jun. - 2025

Version : A1

Issued Stamp :

Customer's Approval Signature

ADAPTER TECHNOLOGY CO.,LTD.

Office (Taiwan) : 6F, No.258, Liancheng Rd., Zhonghe District, New Taipei City 235, Taiwan (R.O.C.)

TEL : +886-2-8226-2279

FAX : +886-2-8226-2238

E-mail : service @adaptech.com.tw ; service_tw @adaptech.com.tw

Factory (China) : BOAYANG ELECTRONICS CO., LTD.

(Philippines) : Adapter Technology Co., Ltd - Philippines Corp.

Elecsys Manufacturing Corporation



5.52 W
AC ADAPTER
SPECIFICATION

Model No. : **ATS005A2-F240P (Level VI)**

Description : **24.0 Volts / 0.23 Amps**

Part No. : **ATS005A2F240P000002**

Version : **A1**

Date : **12 – Jun. – 2025**

| Approved | Reviewed | Checked | Prepared | Sales |
|----------|----------|---------|----------|-------|
| | | | | |



■ Approval Documents/Spec. Revised Records

■ Customer : 株式会社アコン

■ Model No. : ATS005A2-F240P

■ Original Documents Content : SPEC. 10 Page(s) , Attachment 1 Pages

| Revised Records : No. | Date | Description (Before / After) | Page(s) Revised | Revised By (Adapter/Customer) | Remark |
|-----------------------|--------------|--------------------------------|-----------------|-------------------------------|--------|
| 1 | Jun./12/2025 | Issue | - | Jordan | A1 |
| 2 | | | | | |
| 3 | | | | | |
| 4 | | | | | |
| 5 | | | | | |
| 6 | | | | | |
| 7 | | | | | |
| 8 | | | | | |
| 9 | | | | | |
| 10 | | | | | |
| 11 | | | | | |
| 12 | | | | | |
| 13 | | | | | |
| 14 | | | | | |
| 15 | | | | | |
| 16 | | | | | |
| 17 | | | | | |



1. Feature :

- ◆ **Input** : Universal 100 ~ 240 Vac / 50 ~ 60 Hz Input, without any slide switch.
- ◆ **Output** : 24.0 V / 0~0.23 A
- ◆ **Case Dimension** : 37.5(L) * 28 (W) * 21 (H) mm ±1 mm
- ◆ **Efficiency** : Eff (av) ≥ 74.375%
Eff ≥ 65.347% (At 230 V/50 Hz input@10% load for CoC Tier2)
- ◆ **Safety** : UL
- ◆ **EMI** : CE Conduction & radiation Class B
- ◆ **Protection** : OVP (Over Voltage Protection) 、 SCP (Short Circuit Protection) 、 OCP (Over Current Protection)
- ◆ Suitable for usage at I.T.E., industrial controller
- ◆ Meet DoE VI / ErP (Lot 7) / GEMS / NRCan / CEC

2. Input :

| | |
|-----------------------|---|
| 2.1 Voltage | Universal 100~240 Vac, single phase |
| 2.2 Frequency | 50 ~ 60 Hz |
| 2.3 Current | 0.19 A Max. |
| 2.4 Inrush Current | Cold start at 25°C , full load 60 A max. / 240 Vac (ac source chroma 6530) 120 A max. / 230 Vac (mains electricity from wall) |
| 2.5 Efficiency | Eff (av) ≥ 74.375% (At 115 Vac & 230 Vac) Eff ≥ 65.347% (At 230 V/50 Hz input@10% load for CoC Tier2) |
| 2.6 Power Consumption | Pi ≤ 0.1 W (At 115 Vac & 230 Vac & No Load) |

$$\text{※Eff (av)} = \frac{E_1 + E_2 + E_3 + E_4}{4}$$

E1=efficiency with 25% rated load ; E2= efficiency with 50% rated load
E3=efficiency with 75% rated load ; E4= efficiency with 100% rated load

3. Output :

| | | |
|---------------|----------------|---|
| 3.1 DC Output | Voltage | 24.0 V ± 5% |
| | Current | 0.23 A Max. |
| | Regulation | 22.80 Vmin. ~ 24.00 Vtyp. ~ 25.20 Vmax. |
| | Ripple & Noise | 240 mVpp Max. |
| | Total Power | 5.52 W Max. |

Remark : For ripple & noise measurement, use a 20MHz bandwidth frequency oscilloscope, and add a 0.1μF multilayer Cap. and a Low ESR Electrolytic Cap. (47 μF) at output connector terminals. (At nominal line voltage, Full Load)



4. Protection :

| | |
|------------------------------------|--|
| 4.1 Over Voltage Protection (OVP) | 48 V(Max) |
| 4.2 Short Circuit Protection (SCP) | Automatic recovery after short-circuit fault being removed |
| 4.3 Over Current Protection(OCP) | 0.5 A(Max) |

Remark : When Short Circuit Protection or Over Current Protection is activated,the power supply will shutdown automatically.

Once the abnormal condition resulting in the failure being removed, the power supply will restart accordingly. When

Over Voltage Protection is activated, the power supply will shutdown.

5. Safety requirement :

5.1. Dielectric strength : Cut off current 10 mA

| | | |
|-----|----------------------|-----------------------------|
| (1) | Primary to secondary | 3000 Vac (RMS) for 1 minute |
|-----|----------------------|-----------------------------|

5.2. Insulation resistance :

| | | |
|-----|----------------------|-------------------|
| (1) | Primary to secondary | 10 MΩ for 500 Vdc |
|-----|----------------------|-------------------|

5.3 Leakage current : Less than 0.5 mA (RMS) or 0.707 mA (Peak)

6. Operation and Environment Performance :

6.1 Temperature Range

| | |
|-----------|-----------------|
| Operating | - 20°C ~ + 50°C |
| Storage | - 20°C ~ + 80°C |

6.2 Humidity Range(Non-condensing)

| | |
|-----------|--------------|
| Operating | 20% ~ 80% RH |
| Storage | 10% ~ 90% RH |

6.3 Cooling : By natural air.

7. M.T.B.F. : 300,000 Hrs.(Calculated Hours at 25°C,By Telcordia SR-332)

8. Mechanical :

8.1 Weight : 40g Typical

8.4 Case Dimension : 37.5mm(L)*28mm(W)*21mm(H)±1mm

8.5 Material Flammability : UL 94V-0

8.6 External Apperance : As drawing below (Scale → mm)

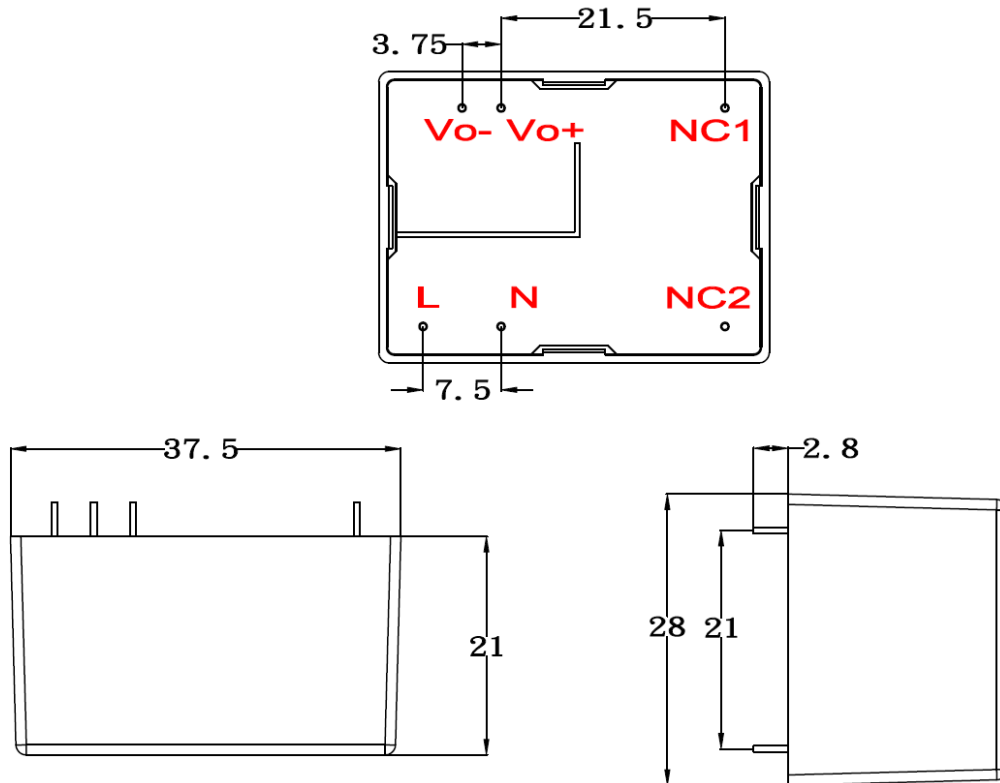

9. LABEL

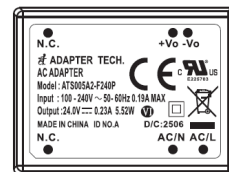
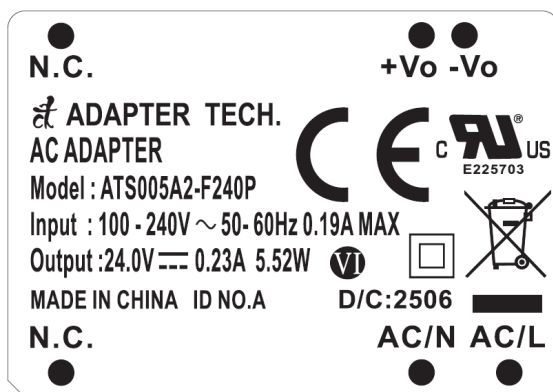

Label Part No. :94LA000410

*Precaution of Safety Distance

L, N, NC1, NC2 are located at the primary side. The total safety distance from the primary side to the touchable surface should be 5.5mm.

The following figure shows the distance that needs to be reserved around the power supply.

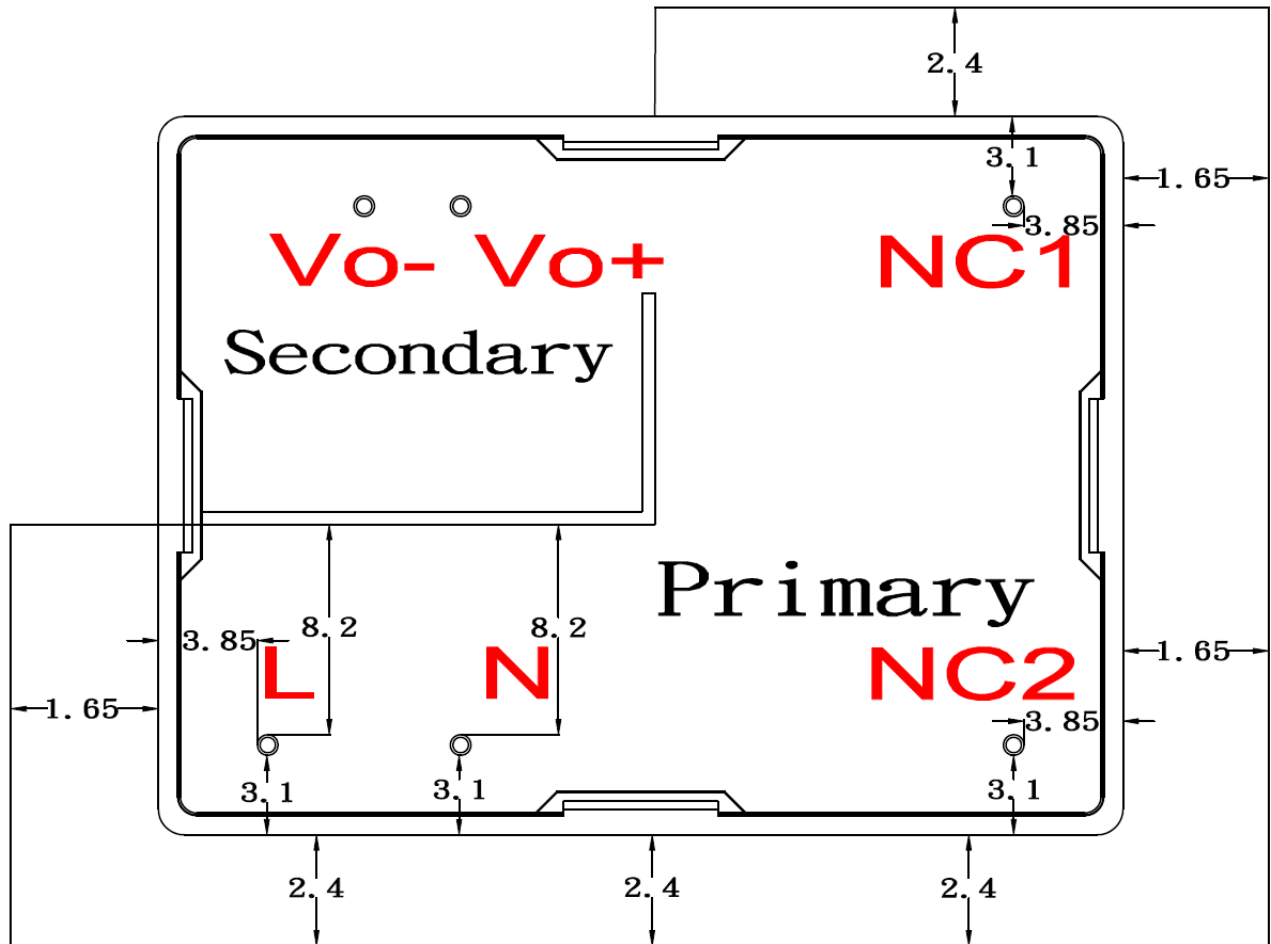

Unit:mm



A. Line Regulation Test

Test Result :

| Test condition | Spec. | Reading 1 | Reading 2 | Reading 3 |
|--------------------|-----------------|-----------|-----------|-----------|
| 90 Vac / 50% Load | 22.8 V ~ 25.2 V | 24.29 V | 24.30 V | 24.29 V |
| 115 Vac / 50% Load | 22.8 V ~ 25.2 V | 24.29 V | 24.30 V | 24.29 V |
| 132 Vac / 50% Load | 22.8 V ~ 25.2 V | 24.29 V | 24.30 V | 24.29 V |
| 180 Vac / 50% Load | 22.8 V ~ 25.2 V | 24.29 V | 24.30 V | 24.29 V |
| 230 Vac / 50% Load | 22.8 V ~ 25.2 V | 24.29 V | 24.30 V | 24.29 V |
| 264 Vac / 50% Load | 22.8 V ~ 25.2 V | 24.29 V | 24.30 V | 24.29 V |

B. Efficiency Test

Test Result :

| Test condition | Spec. | Reading 1 | Reading 2 | Reading 3 |
|------------------|--------------|-----------|-----------|-----------|
| 115 Vac | 74.375% Min. | 84.503% | 84.504% | 84.503% |
| 230 Vac | 74.375% Min. | 83.307% | 83.308% | 83.307% |
| 230 Vac 10% load | 65.347% Min. | 65.776% | 65.777% | 65.776% |

$$\text{Eff (av)} = \frac{E1 + E2 + E3 + E4}{4}$$

E1=efficiency with 25% rated load ; E2= efficiency with 50% rated load
E3=efficiency with 75% rated load ; E4= efficiency with 100% rated load

C. Load Regulation Test

Test Result :

| Test condition | Spec. | Reading 1 | Reading 2 | Reading 3 |
|---------------------|-----------------|-----------|-----------|-----------|
| 115 Vac / 0% Load | 22.8 V ~ 25.2 V | 24.29 V | 24.30 V | 24.29 V |
| 115 Vac / 50% Load | 22.8 V ~ 25.2 V | 24.29 V | 24.30 V | 24.29 V |
| 115 Vac / 100% Load | 22.8 V ~ 25.2 V | 24.29 V | 24.30 V | 24.29 V |
| 230 Vac / 0% Load | 22.8 V ~ 25.2 V | 24.29 V | 24.30 V | 24.29 V |
| 230 Vac / 50% Load | 22.8 V ~ 25.2 V | 24.29 V | 24.30 V | 24.29 V |
| 230 Vac / 100% Load | 22.8 V ~ 25.2 V | 24.29 V | 24.30 V | 24.29 V |



D. Ripple & Noise Test

Test Result :

| Test condition | Spec. | Reading 1 | Reading 2 | Reading 3 |
|---------------------|---------------|-----------|-----------|-----------|
| 115 Vac / 100% Load | 240 mVpp Max. | 86 mVpp | 90 mVpp | 86 mVpp |
| 230 Vac / 100% Load | 240 mVpp Max. | 90 mVpp | 95 mVpp | 90 mVpp |

Remark : For ripple & noise measurement, use a 20MHz bandwidth frequency oscilloscope, and add a 0.1 μ F multilayer Cap. and a Low ESR Electrolytic Cap. (47 μ F) at output connector terminals. (At nominal line voltage, Full Load)

E. Inrush Current

Test Result :

| Test condition | Spec. | Reading 1 | Reading 2 | Reading 3 |
|---------------------|---------------------------|-----------|-----------|-----------|
| 240 Vac / 100% Load | 60 A Max (chroma 6530) | 43.0 A | 42.8 A | 43.2 A |

F. Over Current Protection

Test Result :

| Test condition | Spec. | Reading 1 | Reading 2 | Reading 3 |
|---------------------|---------------|-----------|-----------|-----------|
| 115 Vac / 100% Load | 0.5 A (Max) | 0.37 A | 0.36 A | 0.37 A |
| 230 Vac / 100% Load | 0.5 A (Max) | 0.37 A | 0.36 A | 0.37 A |

G. Short Circuit Protection

Test Result :

| Test condition | Spec. | Reading 1 | Reading 2 | Reading 3 |
|---------------------|---------------|-----------|-----------|-----------|
| 115 Vac / 100% Load | Auto Recovery | OK | OK | OK |
| 230 Vac / 100% Load | Auto Recovery | OK | OK | OK |

H. Input Power Consumption(No Load)

Test Result :

| Test condition | Spec. | Reading 1 | Reading 2 | Reading 3 |
|-------------------|---------------|-----------|-----------|-----------|
| 115 Vac / 0% Load | \leq 0.10 W | 0.050 W | 0.050 W | 0.050 W |
| 230 Vac / 0% Load | \leq 0.10 W | 0.071 W | 0.071 W | 0.071 W |



Adapter Technology Co., Ltd.

Efficiency Test Report

| | | | | | |
|----|---------------------------|--|----------|-------|-------|
| A. | Model Number | : ATS005A2-F240P | 24.0V | 0.23A | 5.52W |
| B. | DC Power Cord | : | | | |
| C. | Average Efficiency | : | | | |
| | Erp (Lot 7) | $0.071 \cdot \ln(P_{out}) - 0.0014 \cdot P_{out} + 0.67 =$ | 74.375% | Min. | |
| | DoE Level VI | $0.071 \cdot \ln(P_{out}) - 0.0014 \cdot P_{out} + 0.67 =$ | 74.375% | Min. | |
| | GEMS Level VI | $0.071 \cdot \ln(P_{out}) - 0.0014 \cdot P_{out} + 0.67 =$ | 74.375% | Min. | |
| | CoC Tier 2 | $0.071 \cdot \ln(P_{no}) - 0.00115 \cdot P_{no} + 0.67 =$ | 74.541% | Min. | |
| | CoC Tier 2 (10% Load) | $0.071 \cdot \ln(P_{no}) - 0.00115 \cdot P_{no} + 0.57 =$ | 65.347% | Min. | |
| D. | NO Load Power Consumption | : | | | |
| | Erp (Lot 7) | 0.1W Max. | | | |
| | DoE Level VI | 0.1W Max. | | | |
| | GEMS Level VI | 0.1W Max. | | | |
| | CoC Tier 2 | 0.075W Max. | | | |
| E. | Testing Equipment | : | | | |
| | a. AC Power Source | : " Zentech " | 2700M-10 | | |
| | b. Electronic Load | : " PRODIGIT " | 3311C | | |
| | c. Power Meter | : " YOKOGAWA " | WT-210A | | |
| | d. Digital Meter | : " FLUKE " | 45 | | |
| F. | AC Input Voltage | : 115Vac/60Hz | | | |

| Load Conditions Reported Quantity | 100%* I ₀ | 75%* I ₀ | 50%* I ₀ | 25%* I ₀ | 10%* I ₀ | 0%* I ₀ |
|--|------------------------|---------------------|---------------------|---------------------|---------------------|--------------------|
| | Rms Output Current(mA) | 230mA | 173mA | 115mA | 58mA | 23mA |
| Rms Output Voltage(V) | 24.290V | 24.290V | 24.290V | 24.290V | 24.290V | 24.290V |
| Active Output Power(W) | 5.59W | 4.19W | 2.79W | 1.40W | 0.56W | 0.00W |
| Rms Input Voltage(V) | 115V | 115V | 115V | 115V | 115V | 115V |
| Rms Input Current(A) | 0.104A | 0.083A | 0.061A | 0.037A | 0.020A | 0.002A |
| Rms Input Power(W) | 6.453W | 4.874W | 3.313W | 1.721W | 0.790W | 0.050W |
| True Power Factor (PF) | 0.543 | 0.518 | 0.474 | 0.408 | 0.353 | 0.026 |
| Total Harmonic Distortion of the input current | 137.3A% | 150.5A% | 172.4A% | 208.5A% | 234.0A% | 20.2A% |
| Power Consumed by UUT(W) | 0.866W | 0.684W | 0.520W | 0.324W | 0.231W | 0.050W |
| Active Efficiency | 86.575% | 85.967% | 84.315% | 81.155% | 70.718% | * |
| Average Efficiency | 84.503% | | | | 70.718% | * |

G. AC Input Voltage : 230Vac/50Hz

| Load Conditions Reported Quantity | 100%* I ₀ | 75%* I ₀ | 50%* I ₀ | 25%* I ₀ | 10%* I ₀ | 0%* I ₀ |
|--|------------------------|---------------------|---------------------|---------------------|---------------------|--------------------|
| | Rms Output Current(mA) | 230mA | 173mA | 115mA | 58mA | 23mA |
| Rms Output Voltage(V) | 24.290V | 24.290V | 24.290V | 24.290V | 24.280V | 24.290V |
| Active Output Power(W) | 5.59W | 4.19W | 2.79W | 1.40W | 0.56W | 0.00W |
| Rms Input Voltage(V) | 230V | 230V | 230V | 230V | 230V | 230V |
| Rms Input Current(A) | 0.068A | 0.055A | 0.410A | 0.025A | 0.015A | 0.001A |
| Rms Input Power(W) | 6.495W | 4.948W | 3.362W | 1.758W | 0.849W | 0.071W |
| True Power Factor (PF) | 0.370 | 0.351 | 0.341 | 0.343 | 0.287 | 0.013 |
| Total Harmonic Distortion of the input current | 230.0A% | 247.7A% | 254.6A% | 257.9A% | 196.7A% | 6.5A% |
| Power Consumed by UUT(W) | 0.908W | 0.758W | 0.569W | 0.361W | 0.291W | 0.071W |
| Active Efficiency | 86.015% | 84.681% | 83.086% | 79.447% | 65.776% | * |
| Average Efficiency | 83.307% | | | | 65.776% | * |

Tester : Jordan



示意圖
(圖面僅供參考)



- 用膠帶封口
- 無需膠帶封口

| REVISIONS | | | | |
|-----------|-----|-------------|----------|----------|
| SHOW | REV | DESCRIPTION | DATE | APPROVED |
| △ | A | 初版制作 | 22/11/28 | Sun |
| | | | | |
| | | | | |

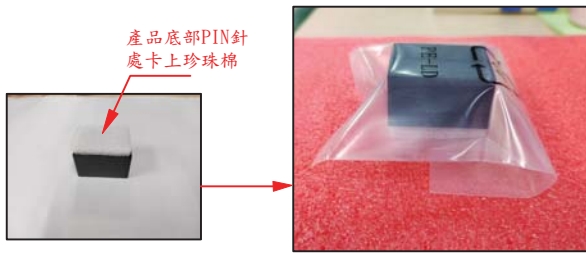
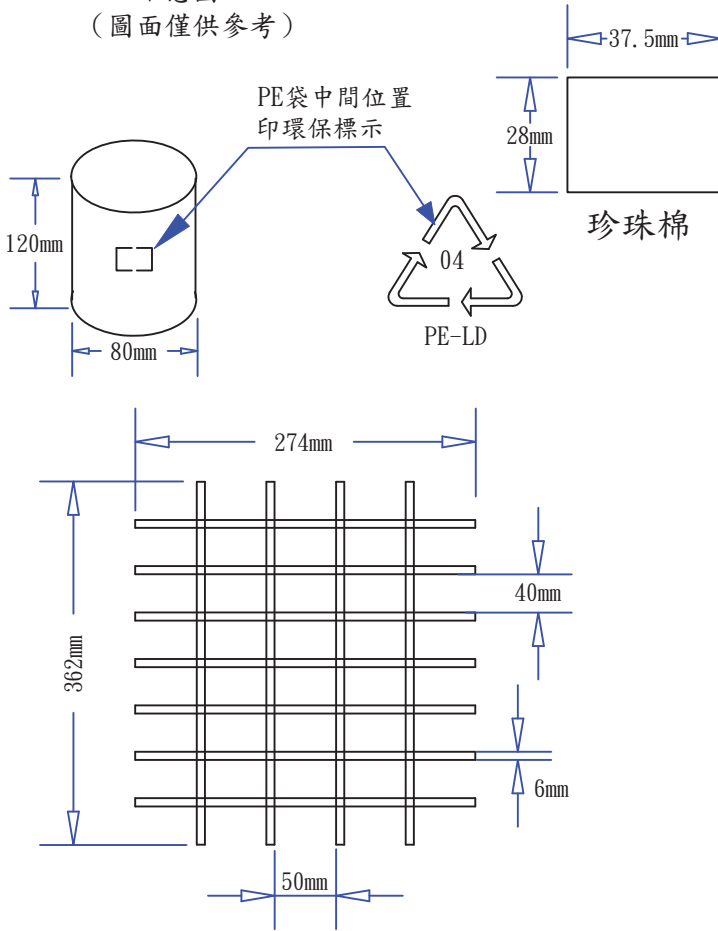
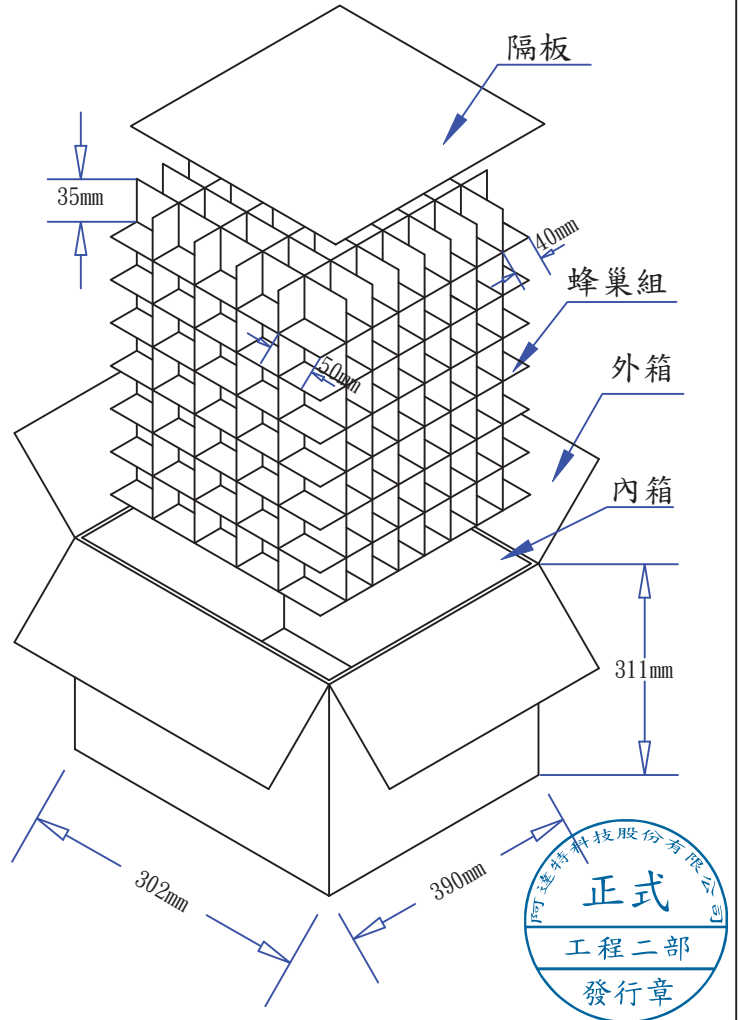

PIS5W000023 包裝(ATS005A2-FxxxP系列)-環保PE袋-珍珠棉-內箱-中分-280

- | | | | |
|-------------------|---|-------|--------|
| <u>9550050301</u> | 1. 隔板:362(L)*274(W)*6mm | K=K | 8/280 |
| | 2. 數量:5*8*7=280 PCS | | |
| <u>9520080101</u> | 3. 外箱:390(L)*302(W)*311(H)mm | K=K | 1/280 |
| <u>9520080001</u> | 4. 內箱:376(L)*288(W)*293(H)mm(無上下蓋) | K=K | 1/280 |
| <u>9560049701</u> | 5. 4刀卡:274(L)*35(W)*6mm(中分) | H7H7H | 49/280 |
| <u>9560049801</u> | 6. 7刀卡:362(L)*35(W)*6mm(中分) | H7H7H | 28/280 |
| <u>9540004401</u> | 7. 環保PE袋:120(L)*80(W)*0.09mm 無色透明,單端開口,中間位置印環保標示. | | 1/1 |
| <u>95G0003301</u> | 8. 珍珠棉:37.5(L)*28(W)*5(H)mm (白色)(18KG)(FOR 產品底部,即PIN針處). | | 1/1 |
| | 9. 先在產品底部PIN針處放上珍珠棉,然後將產品裝入環保PE袋里對折袋口,再將產品LABEL面朝上放入蜂巢內,方向須統一.(如圖所示,圖片僅供參考) | | |
| | 10. 外箱標注為外徑尺寸. | | |
| | 11. 上述物品完全符合RoHS環保標準. | | |

阿達特科技股份有限公司
Adapter Technology Co., Ltd.

| | | | | |
|-------------------------|--------------------------------|----------------------|---------------|------------------|
| DRAWING NO. PIS5W000023 | | APPROVAL 1 BY | | |
| UNIT | MODEL NO. FOR ATS005A2-FxxxP系列 | APPROVAL 2 BY | | |
| mm | FILE NO. ADT-0793 | CHECKED BY(ENGINEER) | Sun | 2022/11/28 |
| SCALE | REV. A | SHEET 1/1 | DRAWN BY | Moon |
| | | | | 2022/11/28 |
| Apply for sales | | Apply for engineer | Use the sales | Use the engineer |
| | | | | |

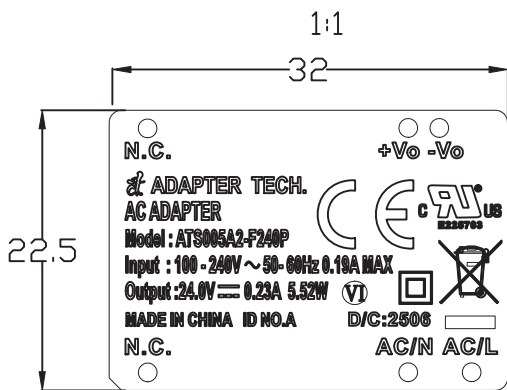
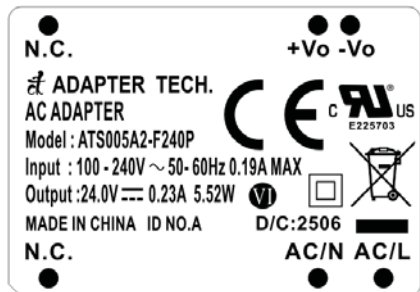

阿達特
2025.06.11
謝宗佐

阿達特
2025.06.11
Steven Liao

PART NO. 94LA000410
Laser Engraving
ATS005A2-F240P V:A

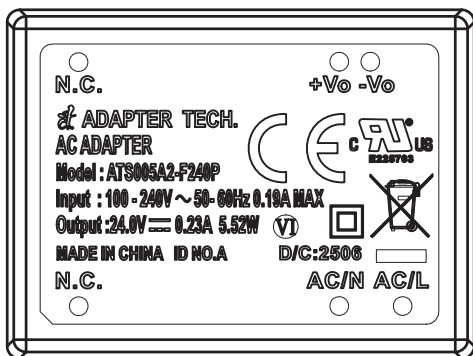



示意圖
(圖面僅供參考)



- 用膠帶封口
- 無需膠帶封口

| REVISIONS | | | | |
|-----------|-----|-------------|----------|----------|
| SHOW | REV | DESCRIPTION | DATE | APPROVED |
| △ | A | 初版制作 | 22/11/28 | Sun |
| | | | | |
| | | | | |

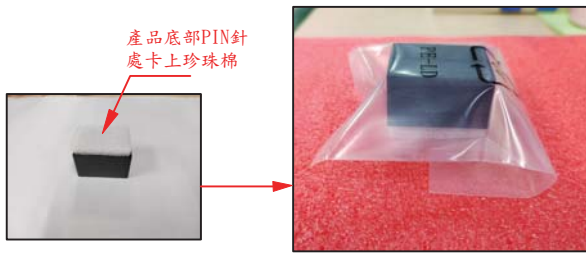
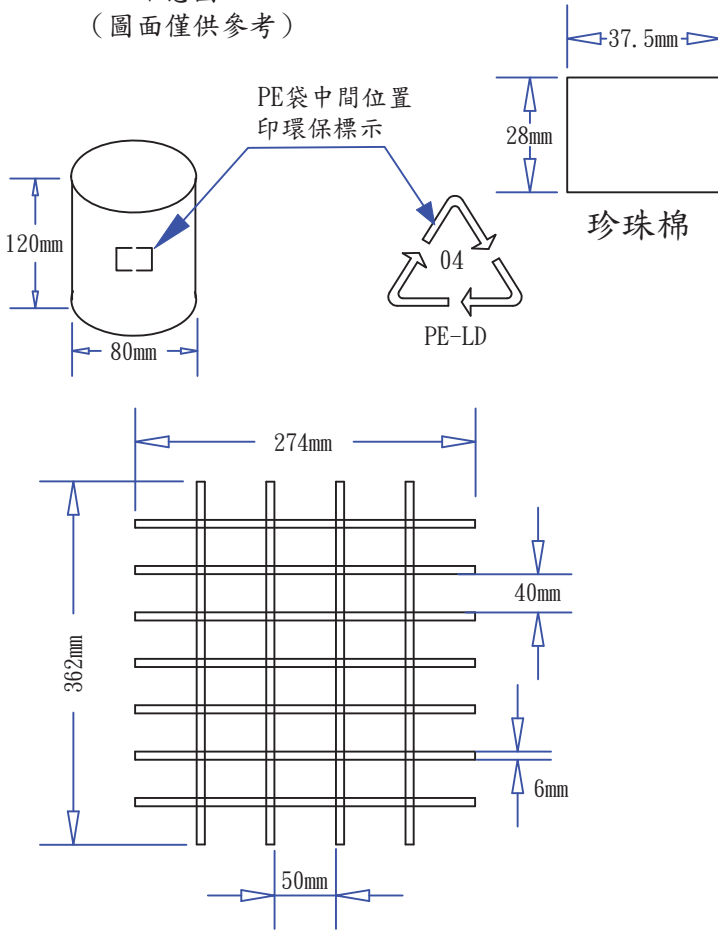
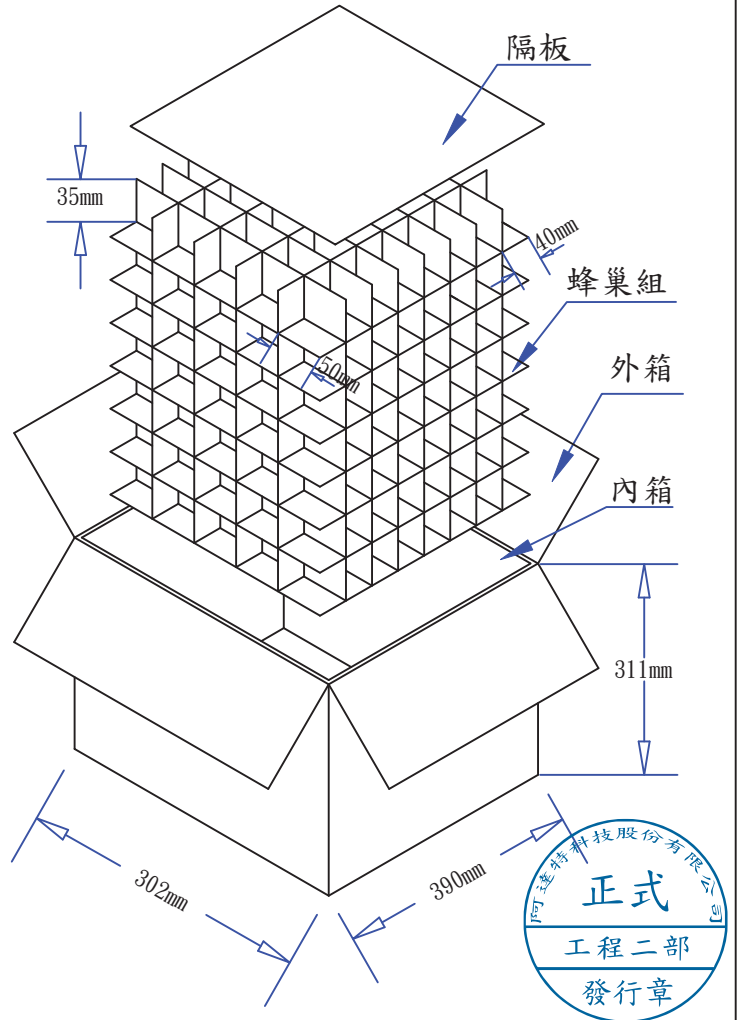

PIS5W000023 包裝(ATS005A2-FxxxP系列)-環保PE袋-珍珠棉-內箱-中分-280

- | | | | |
|-------------------|---|-------|--------|
| <u>9550050301</u> | 1. 隔板:362(L)*274(W)*6mm | K=K | 8/280 |
| <u>9520080101</u> | 2. 數量:5*8*7=280 PCS | | |
| <u>9520080001</u> | 3. 外箱:390(L)*302(W)*311(H)mm | K=K | 1/280 |
| <u>9560049701</u> | 4. 內箱:376(L)*288(W)*293(H)mm(無上下蓋) | K=K | 1/280 |
| <u>9560049801</u> | 5. 4刀卡:274(L)*35(W)*6mm(中分) | H7H7H | 49/280 |
| <u>9540004401</u> | 6. 7刀卡:362(L)*35(W)*6mm(中分) | H7H7H | 28/280 |
| <u>95G0003301</u> | 7. 環保PE袋:120(L)*80(W)*0.09mm 無色透明,單端開口,中間位置印環保標示. | | 1/1 |
| | 8. 珍珠棉:37.5(L)*28(W)*5(H)mm (白色)(18KG)(FOR 產品底部,即PIN針處). | | 1/1 |
| | 9. 先在產品底部PIN針處放上珍珠棉,然後將產品裝入環保PE袋里對折袋口,再將產品LABEL面朝上放入蜂巢內,方向須統一.(如圖所示,圖片僅供參考) | | |
| | 10. 外箱標注為外徑尺寸. | | |
| | 11. 上述物品完全符合RoHS環保標準. | | |

阿達特科技股份有限公司
Adapter Technology Co., Ltd.

| | | | | |
|-------------------------|--------------------------------|--------------------------|----------------------------------|--------------------------|
| DRAWING NO. PIS5W000023 | | APPROVAL 1 BY | | |
| UNIT | MODEL NO. FOR ATS005A2-FxxxP系列 | APPROVAL 2 BY | | |
| mm | FILE NO. ADT-0793 | CHECKED BY(ENGINEER) | Sun | 2022/11/28 |
| SCALE | REV. A | SHEET 1/1 | DRAWN BY | Moon |
| | | | | 2022/11/28 |
| Apply for sales | | Apply for engineer | Use the sales | Use the engineer |
| | | 阿達特 2022.11.29 謝宗佐 | 阿達特 2025.06.11 Steven Liao | 阿達特 2025.06.11 謝宗佐 |