

ZAMF-2000-Bxx Series

2000W, AC/DC 2000W Enclosed Switching Power Supply

DESCRIPTIONS

ZAMF-2000-Bxx series is one of enclosed AC-DC switching power supply. It features universal AC input and at the same time accepts DC input voltage, cost-effective, low no load power consumption, high efficiency, high reliability and double or reinforced insulation. These converters offer excellent EMC performance and meet CISPR32/EN55032, IEC/UL62368, UL60601, GB4943, standards.



 EN62368-1 Report RoHS

FEATURES

- Universal 85 - 277VAC or 120 - 390VDC Input voltage
- Wide adjustable output voltage range
- Accepts AC or DC input (dual-use of same terminal)
- Operating ambient temperature range: -40°C to +85°C
- High efficiency, high reliability
- Active PFC
- High I/O isolation test voltage up to 4000VAC
- Supports 3+1 parallel redundancy
- Supports 485 communication, remote shutdown (PS-ON/OFF)
- Output short circuit, over-current, over-voltage, over-temperature protection
- Operating altitude up to 5000m
- Comply with CISPR32/EN55032, IEC/UL62368, UL60601, GB4943

APPLICATIONS

- Industrial control
- LED
- street light control
- Electricity
- Security
- Telecommunications
- medical
- smart home

Selection Guide

Certification	Part No.	Output Power (W)	nominal Output Voltage and Current (vo/lo)			Adjustable Range of Output Voltage Vo1(V)		Efficiency 230VAC (%) Typ.	Maximum Capacitive Load at normal temperature (μF)	
			Vo1/Io1	Vo2/Io2	Vo3/Io3	ADJ	Vprog		Vo1	Vo2
EN	ZAMF-2000-B12	1211	12V/100A	12V/0.8A	5V/0.3A	10.5-14	7.2-14	91	18000	800
	ZAMF-2000-B24	1931	24V/80A	12V/0.8A	5V/0.3A	20-28	9.6-28	92	15000	800
	ZAMF-2000-B48	2027	48V/42A	12V/0.8A	5V/0.3A	42-56	19.2-56	92	10000	800

Note: The product picture is for reference only. For details, please refer to the actual product.

ZAMF-2000-Bxx Series

2000W, AC/DC 2000W Enclosed Switching Power Supply

Specifications

Specifications	Item	Operating Conditions	Min.	Typ.	Max.	Unit	
Input Specifications	Input Voltage Range	Rated Input (Certified voltage)	100	--	240	VAC	
		AC Input	85	--	277		
		DC Input	120	--	390	VDC	
	Input Voltage Frequency	Rated Input (Certified voltage)	47	--	63	Hz	
		AC Input	47	--	63		
	Input Current	Rated Input (Certified voltage)	--	--	18.5	A	
		115VAC	--	--	17		
		230VAC	--	--	12		
	Inrush Current	115VAC 230VAC	Cold start	--	20	--	
				--	40	--	
	Power Factor	115VAC	Normal temperature, full load	PF ≥ 0.99			
		230VAC		PF ≥ 0.95			
	Start-up Delay Time	115VAC/230VAC, normal temperature, rated load		--	--	3	s
	Input Fuse*	Built-in fuse		--	25	--	A
Input Under-voltage Protection	Under-voltage protection start (Input voltage drops from high to low)		45	65	75	VAC	
	Under-voltage protection release (Input voltage rises from low to high)		70	80	85		
Hot Plug	Unavailable						
Output Specifications	Output Voltage Accuracy	Full load range		--	±1	--	%
	Line Regulation	Rated load		--	±0.5	--	
	Load Regulation	0% - 100% load		--	±0.5	--	
	Minimum Load			0	--	--	
	Ripple & Noise*	12V	Vo1	--	--	150	mV
			Vo2	--	--	150	
		24V	Vo1	--	--	200	
			Vo2	--	--	150	
		48V	Vo1	--	--	300	
			Vo2	--	--	150	
	Temperature Coefficient			--	±0.03	--	%/°C
	Hold-up Time	115VAC/230VAC, rated load		--	14	--	ms
	Short Circuit Protection	Output voltage turn off, re-power on for recover					
	Over-current Protection	105%Io-125%Io, constant current limit mode, output voltage turn off after 5S, re-power on for recover					
Over-voltage Protection	12V		≤25VDC (Output voltage turn off, re-power on for recover)				
	24V		≤35VDC (Output voltage turn off, re-power on for recover)				
	48V		≤63VDC (Output voltage turn off, re-power on for recover)				
Over-temperature Protection	230VAC, 100% load	Over-temperature protection start	--	--	65	°C	
		Over-temperature protection release	50	--	--		
General Specifications	Isolation Test	Input - ⊕	Electric strength test for 1min., leakage current <10mA		2000	--	VAC
		Input - output			4000	--	
		Output - ⊕			1500	--	
	Insulation	Input - ⊕	Ambient temperature: 25 ± 5°C		100	--	MΩ

ZAMF-2000-Bxx Series

2000W, AC/DC 2000W Enclosed Switching Power Supply

Resistance	Input - output	Relative humidity: < 95%RH, no condensation Test voltage: 500VDC	100	--	--		
	Output - ⊕		100	--	--		
Isolation level	Input - output	2 x MOPP					
	Input - ⊕	1 x MOPP					
	Output - ⊕	1 x MOPP					
Operating Temperature			-40	--	85	°C	
Storage Temperature			-40	--	85		
Operating Humidity		Non-condensing	10	--	95	%RH	
Storage Humidity			20	--	90		
Switching Frequency	PFC		--	65	--	KHz	
	DC-DC		--	82	--		
	Auxiliary source		--	65	--		
Power Derating	Operating temperature derating		-40°C to -25°C*	0	--	--	% / °C
			-25°C to +50°C	0	--	--	
			+50°C to +85°C	2.5	--	--	
	Input voltage derating	AC Input (12V)	85VAC-180VAC	0.211	--	--	% / VAC
			180VAC-277VAC	0	--	--	
		DC Input (12V)	120VDC-350VDC	0.261	--	--	% / VDC
			350VDC-390VDC	0	--	--	
		AC Input (24/48V)	85VAC-100VAC	1	--	--	% / VAC
			100VAC-180VAC	0.31	--	--	
	180VAC-277VAC		0	--	--		
DC Input (24/48V)	120VDC-350VDC	0.304	--	--	% / VDC		
	350VDC-390VDC	0	--	--			
Leakage Current	240VAC, 60Hz		Touch current	<0.1mA			
			Earth leakage current	<0.5mA			
Safety Class			CLASS I				
MTBF		MIL-HDBK-217F@25°C	≥250,000 h				
Warranty		Ambient temperature: ≤85°C	5 years				
Mechanical Specifications	Case Material		Metal (SUS 304)				
	Dimensions		290.00mm x 127.00mm x 40.50mm				
	Weight		2100g (Typ.)				
	Cooling Method		Forced cooling 17.15 CFM				
<p>Note:1 *The fuse is in the neutral of the mains supply, the mains shall be disconnected to de-energize the phase conductors. 2. *The "Tip and barrel method" is used for ripple and noise test, output parallel 47uF electrolytic capacitor and 0.1uF ceramic capacitor, please refer to Enclosed Switching Power Supply Application Notes for specific information. 3. The product has a built-in fan, which cannot be shipped by air; 4. *Vin ≥ 180Vac.</p>							

ZAMF-2000-Bxx Series

2000W, AC/DC 2000W Enclosed Switching Power Supply

Electromagnetic Compatibility (EMC)

Electromagnetic Compatibility (EMC)	Emissions	CE	CISPR32 EN55032	150kHz—30MHz	CLASS B
		RE	CISPR32 EN55032	30MHz—1GHz	CLASS A
		Harmonic current	IEC/EN61000-3-2		CLASS A and CLASS D
	Immunity*	ESD	IEC/EN61000-4-2	Contact ±8KV/Air ±15KV	Perf. Criteria A
		RS	IEC/EN61000-4-3	80MHz – 1GHz 10V/m	
		EFT	IEC/EN61000-4-4	±4KV, (5 or 100)kHz	
		Surge	IEC/EN61000-4-5	line - line ±2KV/line - PE ±4KV	
		MS	IEC/EN61000-4-8	30A/m	
		CS	IEC/EN61000-4-6	0.15MHz - 80MHz 10Vr.m.s	
		Voltage dips	IEC/EN61000-4-11	70% U _n [*] , 25/30 periods (50/60Hz) 40% U _n [*] , 10/12 periods (50/60Hz) 0% U _n [*] , 1 periods	Perf. Criteria B

Note: 1. *U_n is the maximum input nominal voltage,

2. *perf. Criteria:

A: The equipment shall continue to operate as intended without operator intervention;

B: After the test, the equipment shall continue to operate as intended without operator intervention;

C: Loss of function is allowed, provided the function is self-recoverable, or can be restored by the operation of the controls by the user in accordance with the manufacturer's instructions.

Functional Specifications

Functional Specifications	Item	Operating Conditions		Min.	Typ.	Max.	Unit
	Remote Control Switch	All input voltage range, all load range	Power on	P1300 Pin13 and Pin4 short			
	Power off		P1300 Pin13 and Pin4 open				
DC-OK Signal	All input voltage range, all load range	Power on	--	0	0.5	V	
		Power off	10	--	12		
Current Sharing Accuracy	Output >50%Io1		--	±10	--	%	
Remote Sense	The total compensated voltage value of Vs+ and Vs- (Pin9 and Pin18 of the JP1300) when they are shorted to both ends of the output load (Vs+ to +Vo1, Vs- to -Vo1) respectively		--	200	--	mV	
Oring			Support direct parallel use, achieve 3+1 parallel redundancy				
LED Signal	Main output status indication	Normal output	Green on				
		Abnormal output, protected	Red on				
		Power off (AC without Input)	Light off				
SDA, SCL for I ² C*	Pin5 and Pin6 of the JP1300		Internal 2.4 k Ω pull-up resistor to internal 3.3V				

Note:*SDA, SCL for I²C, this function is reserved. If you need this function, you can contact the sales engineer for customized development.

ZAMF-2000-Bxx Series

2000W, AC/DC 2000W Enclosed Switching Power Supply

Characteristic Curve

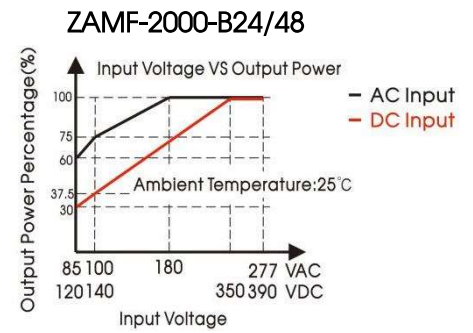
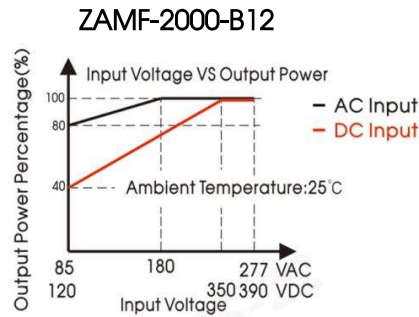
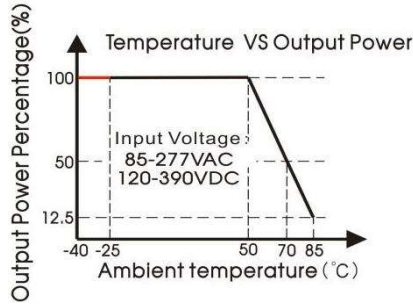

* $V_{in} \geq 180VAC$

Note: 1. With an AC input voltage between 85 - 180VAC and a DC input between 120 - 350VDC the output power must be derated as per the temperature derating curves;

2. This product is suitable for applications using natural air cooling;.

Efficiency Vs Input Voltage (Full Load)

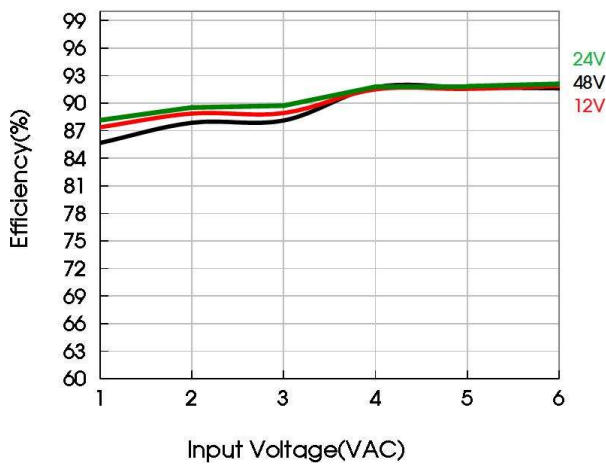

Efficiency Vs Output Load (Vin=230VAC)

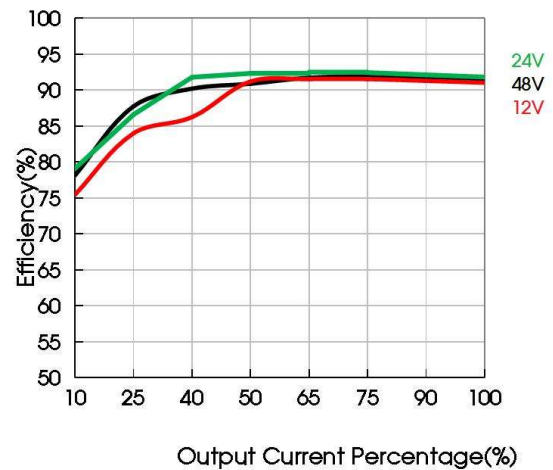

ZAMF-2000-Bxx Series

2000W, AC/DC 2000W Enclosed Switching Power Supply

Dimensions and Recommended

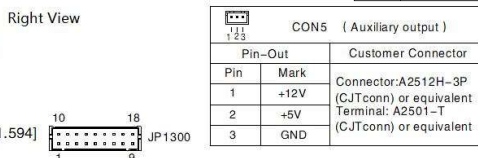
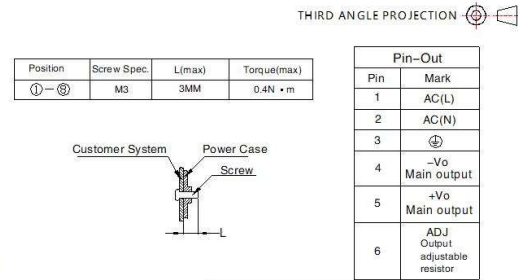
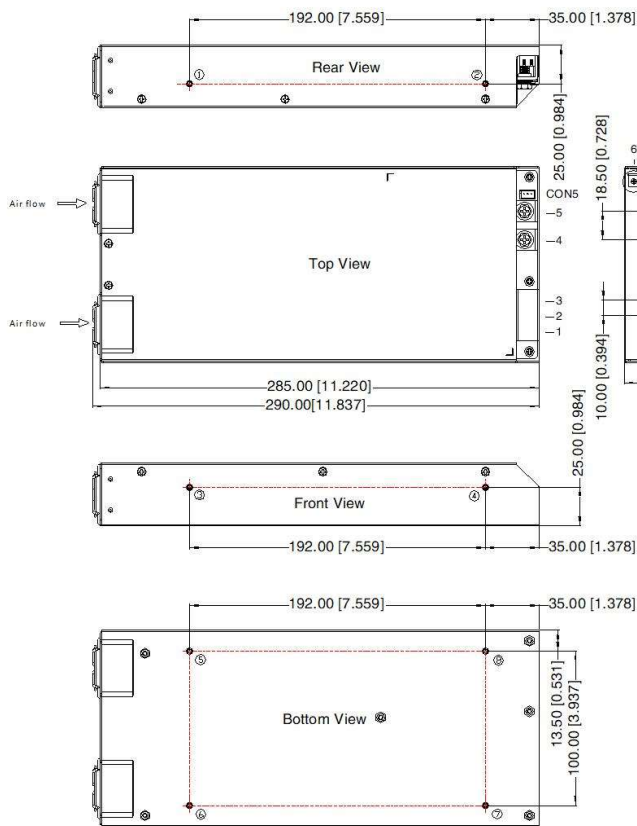

Pin-Out				Customer Connector
Pin	Mark	Pin	Mark	
1	RGND	10	RS485_H	Connector:JST PHDR-18VS or equivalent Terminal:JST SPHD-002T-P0.5 or equivalent
2	/	11	RS485_L	
3	VPROG	12	/	
4	PS_ON/OFF	13	SGND	
5	SDA	14	Current share	
6	SCL	15	A2	
7	DC_OK	16	A1	
8	AC_OK	17	A0	
9	VS+	18	VS-	

Connector wires range

Pro. No	Input connector(Pin1,2,3)	Output connector(Pin4,5)
12V	16-10AWG	4-2AWG
24V		4-2AWG
48V		8-2AWG
Screw/torque	M4/Max 0.9N · m	M5/Max 2.3N · m

Note:
 Unit: mm[inch]
 General tolerances: ± 1.00[± 0.039]

- Note:
- Unless otherwise specified, parameters in this datasheet were measured under the conditions of $T_a=25^{\circ}\text{C}$, humidity <75%RH with nominal input voltage and rated output load;
 - The room temperature derating of $5^{\circ}\text{C}/1000\text{m}$ is needed for operating altitude greater than 2000m;
 - All index testing methods in this datasheet are based on our company corporate standards;
 - In order to improve the efficiency at high input voltage, there will be audible noise generated, but it does not affect product performance and reliability;
 - We can provide product customization service, please contact our technicians directly for specific information;
 - Products are related to laws and regulations: see "Features" and "EMC";
 - The out case needs to be connected to PE (\perp) of system when the terminal equipment in operating;
 - The output voltage can be adjusted by the ADJ, clockwise to increase;
 - Our products shall be classified according to ISO14001 and related environmental laws and regulations, and shall be handled by qualified units;
 - The power supply is considered a component which will be installed into a terminal equipment. All EMC tests should be confirmed with the final equipment.
 - Packaging bag number: 58220711V

ZAMF-2000-Bxx Series

2000W, AC/DC 2000W Enclosed Switching Power Supply

ZAMF-2000-Bxx Power Supply Application Note

Content

1. Overview description	9
1.1 AC/DC input terminal block (J1)	10
1.2 Main DC output terminal (-Vo1, +Vo1)	10
1.3 Auxiliary DC output terminal CON5	11
1.4 Signal port (JP1300)	11
1.5 Green and red status display LED lights	12
1.6 Adjustable Resistors	12
2. Function Manual	14
2.1 Input requirements	14
2.2 Output requirements	14
2.3 Start-up timing	14
2.4 Fan speed control	15
2.5 Output over-voltage protection (OVP)	15
2.6 Output constant-current protection (OCP)	16
2.7 Output short circuit protection (SCP)	17
2.8 Over-temperature protection (OTP)	17
2.9 Output power derating	17
2.10 Remote control	18
2.11 DC_OK signal	18
2.12 Remote compensation	19
2.13 Parallel operation	20
2.13.1 Redundancy	20
2.13.2 Current sharing	20
2.14 I2C communication address	22
3. Installation requirements	23
3.1 Safety introduction	23
3.2 Safety requirements	24

ZAMF-2000-Bxx Series

2000W, AC/DC 2000W Enclosed Switching Power Supply

3.3 Installation method	24
4.Communication protocol	25
4.1 Hardware parameter	25
4.2 Data frame format	25
4.3 Register data definition	26

ZAMF-2000-Bxx Series

2000W, AC/DC 2000W Enclosed Switching Power Supply

1. Overview description

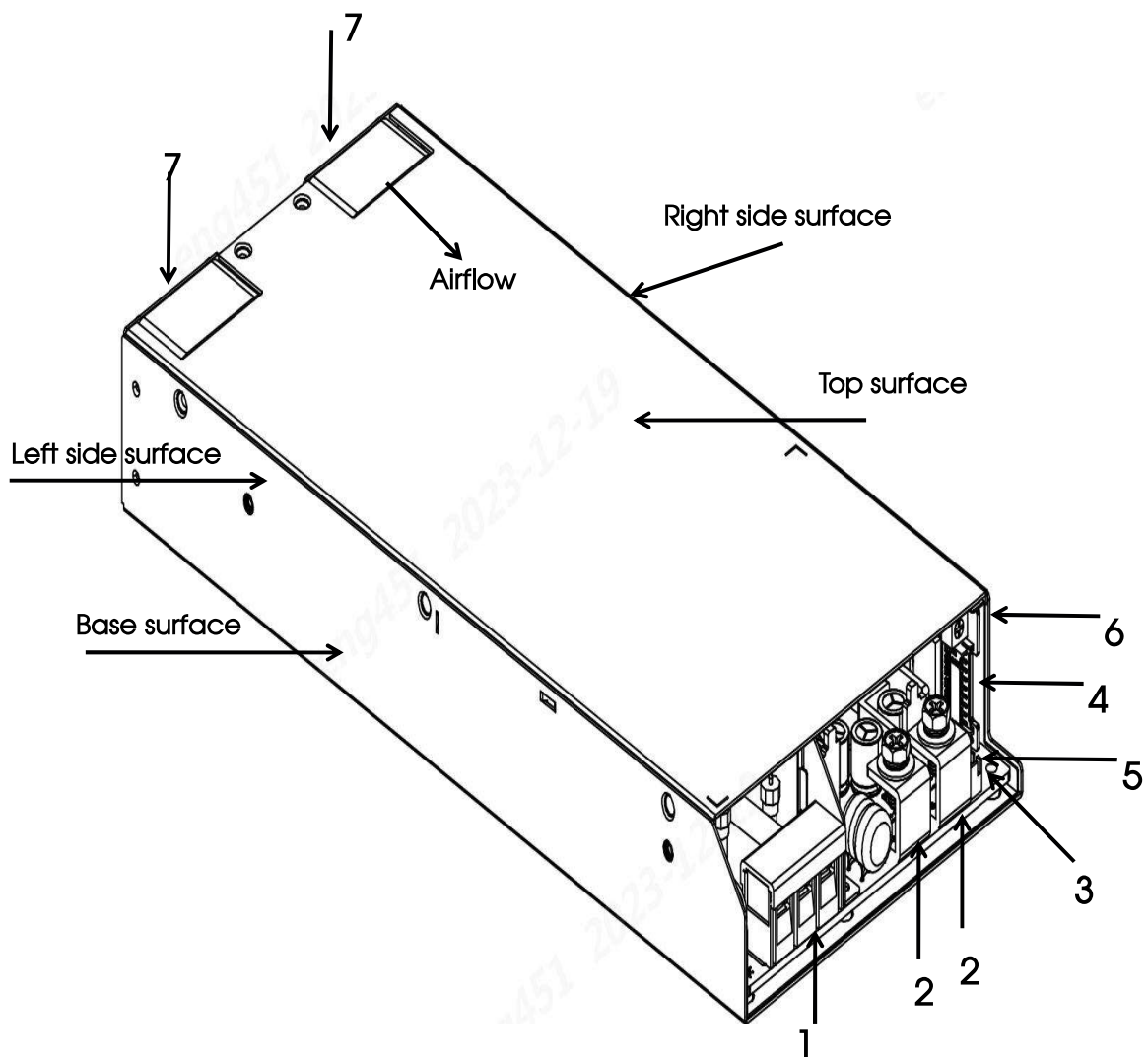

Fig. 1: Appearance information of ZAMF-2000-Bxx
Overview description:

1. AC/DC input terminal (J1)
2. DC main output terminal (-Vo1, +Vo1)
3. Auxiliary output terminal CON5
4. Signal connection press the terminal (JP1300)
5. Green and red status display LED lights
6. Output voltage regulation resistor
7. Fans

ZAMF-2000-Bxx Series

2000W, AC/DC 2000W Enclosed Switching Power Supply

1.1 AC/DC input terminal block (J1)

The input terminal J1, as a standard 3-pin fence welding terminal with upper cover, the center spacing of the pins is 10mm.

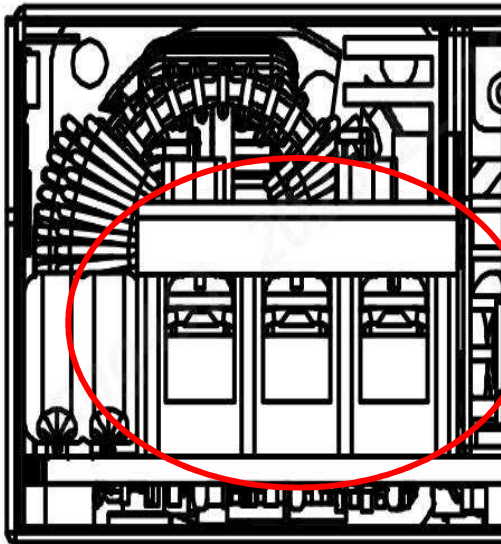

Pin	Features
L	Line (Phase)
N	Neutral
	Ground/Earth

J1

Wire size: 16-10AWG

Torque: M4/0.9N·m (max)

1.2 Main DC output terminal (-Vo1, +Vo1)

The output terminal uses two standard screw lock type metal terminals, the pin spacing between each is 18mm.

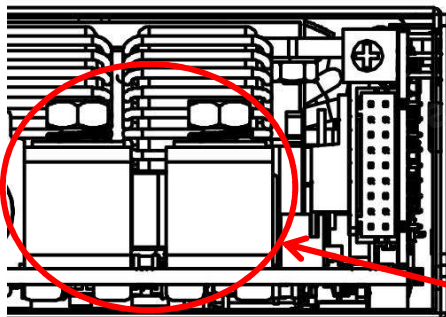

Pin	Features
-Vo1	Main output -
+Vo1	Main output +

-Vo1 +Vo1

Torque: M5/2.3N·m (max)

ZAMF-2000-Bxx Series

2000W, AC/DC 2000W Enclosed Switching Power Supply

1.3 Auxiliary DC output terminal CON5

The auxiliary output terminal with a standard terminal of 2.5mm pitch.

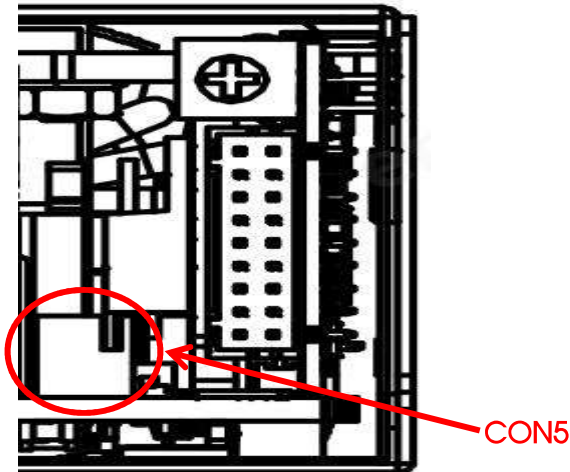

Pin	Label	Function
1	+12V	Vo2+ (12V+)
2	+5V	Vo3+ (5V+)
3	GND	Reference Ground

1.4 Signal port (JP1300)

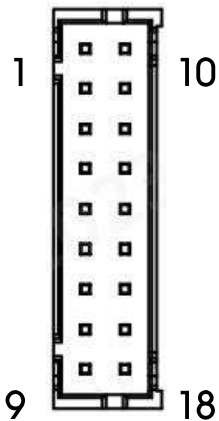

Pin	Label	Features
1	RGND	485 signal ground
2	/	/
3	VPROG	The software output is adjustable
4	PS-ON/OFF	Remote control signal
5	SDA	I2C communication line
6	SCL	I2C communication line
7	DC_OK	DC_OK Signal
8	AC_OK	AC_OK Signal
9	VS+	Remote compensation positive terminal
10	RS485_H	RS485_H
11	RS485_L	RS485_L
12	/	/
13	SGND	Signal terminal reference ground
14	Current share	Current sharing bus
15	A2	ADDRESS code 2
16	A1	ADDRESS code 1
17	A0	ADDRESS code 0
18	VS-	Remote compensation negative terminal

Note: The reference ground of all pins on the signal terminal is Pin13.

ZAMF-2000-Bxx Series

2000W, AC/DC 2000W Enclosed Switching Power Supply

1.5 Green and red status display LED lights

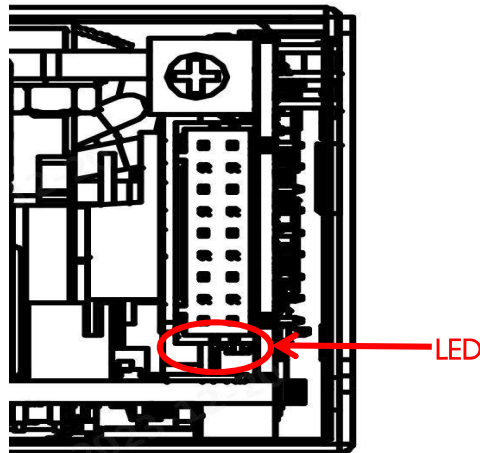

Two kinds of LED lights indicate difference working states of the power supply:

Green LED	Red LED	Status
ON	OFF	Normal work
OFF	ON	Main alarm
OFF	OFF	No input

1.6 Adjustable Resistors

Turn counterclockwise to increase output voltage

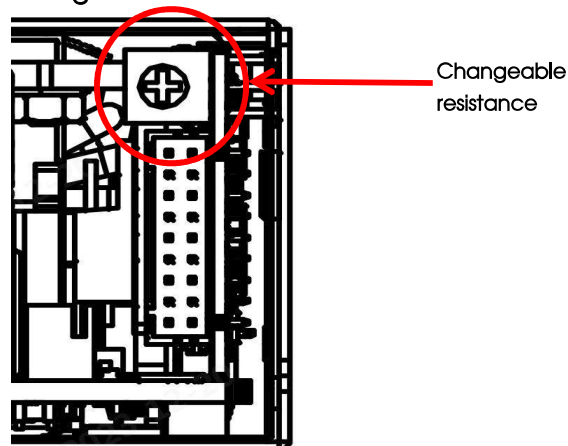

ZAMF-2000-Bxx Series

2000W, AC/DC 2000W Enclosed Switching Power Supply

Model	Rated Output Voltage	Adjustable Range Of Output Voltage
ZAMF-2000-B12	12V	10.5-14V
ZAMF-2000-B24	24V	20-28V
ZAMF-2000-B48	48V	42V-56V

For wider output voltage regulation (beyond the range of adjustable resistor regulation) as shown in the following table, you can use the following methods:

Model	Rated Output Voltage	Adjustable Range Of Output Voltage
ZAMF-2000-B12	12V	7.2-14V
ZAMF-2000-B24	24V	9.6-28V
ZAMF-2000-B48	48V	19.2V-56V

Method : Signal voltage regulation

Connect PIN3 (VPROG) on the JP1300 terminal to 0V and adjust the adjustable resistance to the lowest output voltage. When PIN3 (VPROG) is externally connected to 5V and the adjustable resistance is adjusted to the maximum, it corresponds to the highest output voltage.

For example, the selection of ZAMF-2000-B48, rated output 48Vdc, need to adjust to 19.2Vdc, the operation is as follows; the signal voltage to 0Vdc, and at the same time adjust the adjustable resistor to the minimum voltage counterclockwise, then the output will become 19.2Vdc.

ZAMF-2000-Bxx Series

2000W, AC/DC 2000W Enclosed Switching Power Supply

2. Function Manual

2.1 Input requirements

The AC input voltage and DC input voltage must be within the defined voltage range (refer to data-sheet), otherwise the power supply may not work properly or even malfunction. The internal L and N line of the power module have been connected in series with a 300V 25A fuse. For better protection, it is recommended that customers use a circuit breaker not greater than 25A (Non-mandatory requirement).

2.2 Output requirements

Main output

At any voltage value, the maximum output current and power must not exceed the rated/specified value. The output current must not exceed the maximum output current value.

Auxiliary output

The auxiliary1# circuit supports a maximum current of 12V/0.8A. The auxiliary2# circuit supports a maximum current of 5V/0.3A

2.3 Start-up timing

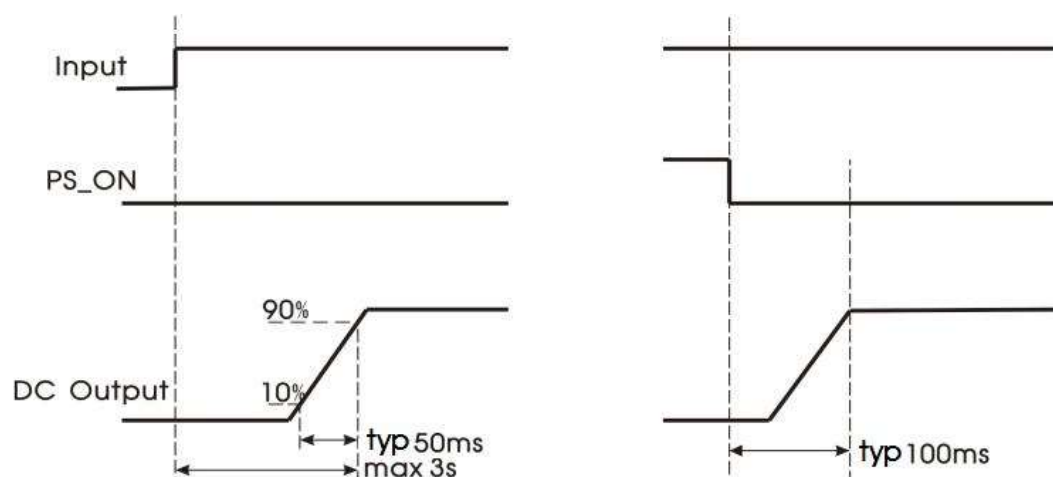

ZAMF-2000-Bxx Series

2000W, AC/DC 2000W Enclosed Switching Power Supply

Item	Operating Conditions		Min.	Typ.	Max.	Unit
Power-off Hold Time	Room temperature, full load	115VAC	14	--	--	ms
		230VAC	14	--	--	
Start Delay Time	230VAC, full load, 25°C		--	--	3	s

2.4 Fan speed control

Fan speed is determined by output power and output voltage at the same time, refer to the following curve for fan speed change.

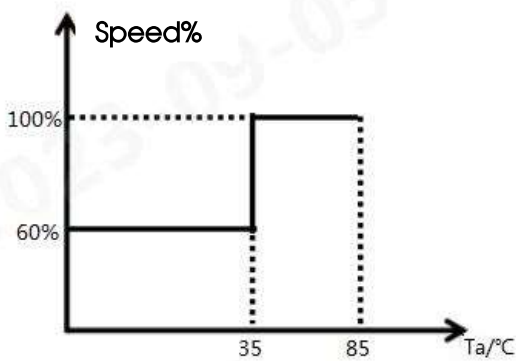

Fig.1

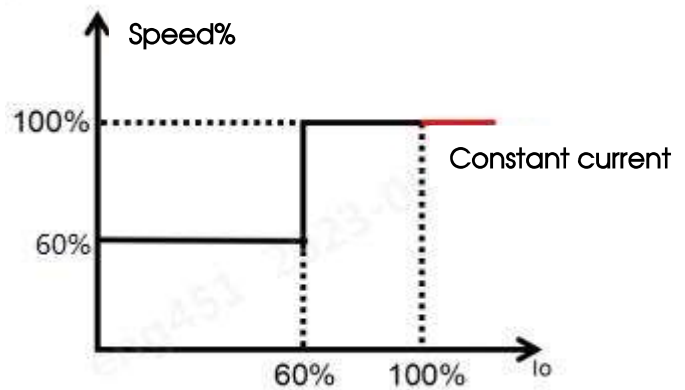

Fig.2

Io: Rated output current. Ta: Near output ambient temperature.

2.5 Output over-voltage protection (OVP)

Main output

The over-voltage protection function is to close the main output when the output voltage reaches the protection voltage value. When the main circuit over-voltage protection occurs, the main circuit output voltage of the module will be shut off, and the auxiliary circuit output will not be affected. The main circuit output can be restored after disconnecting the input power for at least 3 seconds.

ZAMF-2000-Bxx Series

2000W, AC/DC 2000W Enclosed Switching Power Supply

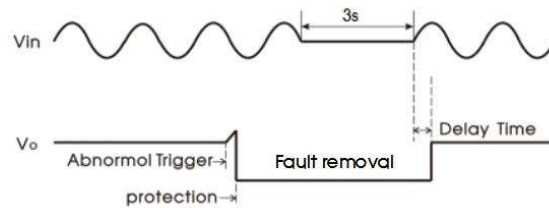

In addition, it can be quickly restarted by the PS_ON signal:

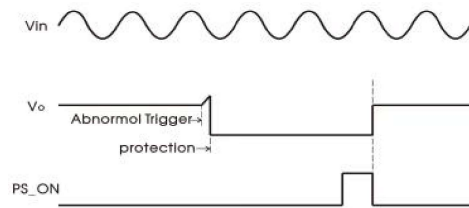

Auxiliary output

When the auxiliary circuit voltage reaches 16VDC (maximum value), the auxiliary output will be in hiccup status, and the main output voltage will be in hiccup status until the auxiliary output returns to normal after the fault is eliminated.

2.6 Output constant-current protection (OCP)

① Main circuit overcurrent

If in CC load mode, when the current exceeds the constant current point, the output enters CC mode 5s (typ.) then shut off; after mains restart, the output returns to normal.

If in CV/CR load mode, the relationship among output current, voltage and resistance is shown in the following curve:

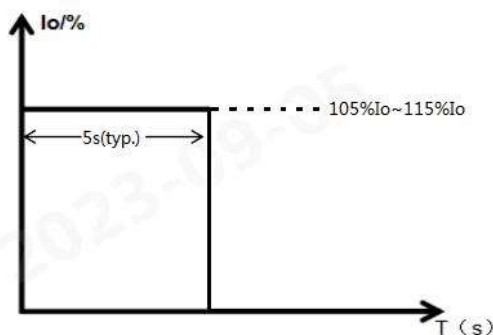

Fig.1

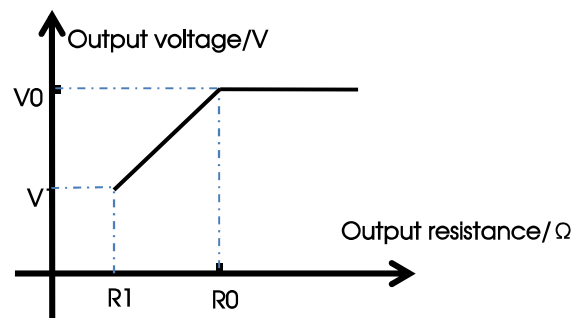

Fig.2

ZAMF-2000-Bxx Series

2000W, AC/DC 2000W Enclosed Switching Power Supply

When the product enters the constant current state, the output state circulates as shown in Fig.1, Enter the 5s constant current state, and then the output is locked. After restarting the power supply and the output overload state is lifted, the product returns to normal working state.

In Fig.2, the corresponding slope of segments R1-R0 is the corresponding output current I when the current is constant.

② Auxiliary circuit overcurrent

When the auxiliary output current exceeds 130% (typ.) of the rated current, turn off the main output. After the overflows state is removed, the main route automatically recovers output after restart.

2.7 Output short circuit protection (SCP)

When the main output is short-circuited, the power output is in constant current state. Fig.1 shows 2.6, after the short-circuit is removed, the mains restart, the output returns to normal.

When the auxiliary circuit output is short-circuited, the main circuit without output.

2.8 Over-temperature protection (OTP)

When the ambient temperature of the power supply exceeds the rated temperature for a period of time, the power supply will be turned off and the power supply will resume normal operation after the ambient temperature drops to the set value.

2.9 Output power derating

The temperature derating curve and voltage derating should be performed according to the following curves.

ZAMF-2000-Bxx Series

2000W, AC/DC 2000W Enclosed Switching Power Supply

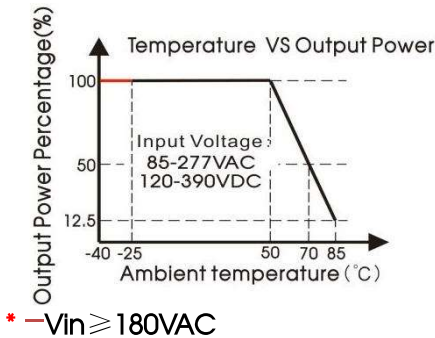

* $V_{in} \geq 180VAC$

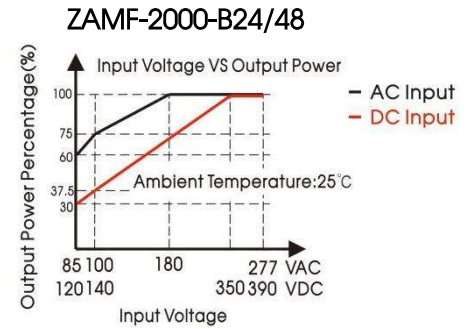
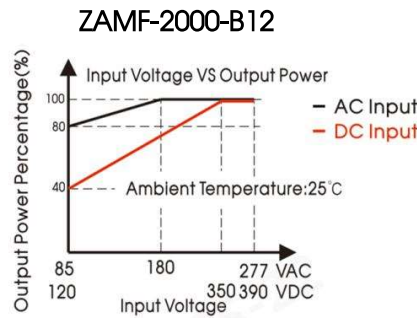

2.10 Remote control

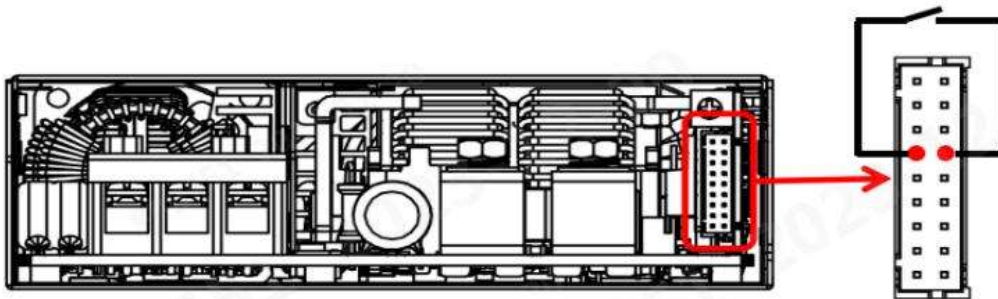

Switch between PS_ON/OFF (Pin4) and SGND (Pin13)	Output Status
Short-Circuit	Output on
Pin floating	Output off

If the input terminal of the power module has been connected to a power source, the PS_ON/OFF signal pin can be used to control the on and off of the main output, and the PS_ON/OFF signal does not affect the output voltage of the auxiliary circuit.

Note: The internal PS_ON/OFF input impedance of the module is 5.1K.

2.11 DC_OK signal

The DC_OK signal is used to monitor whether the power supply is working normally, and the signal is at Pin7 of the signal terminal JP1300.

Note: When the DC_OK signal is connected to the external circuit, the impedance of the external external circuit (between Pin7 and Pin13 of JP1300) is not less than 10k Ω .

ZAMF-2000-Bxx Series

2000W, AC/DC 2000W Enclosed Switching Power Supply

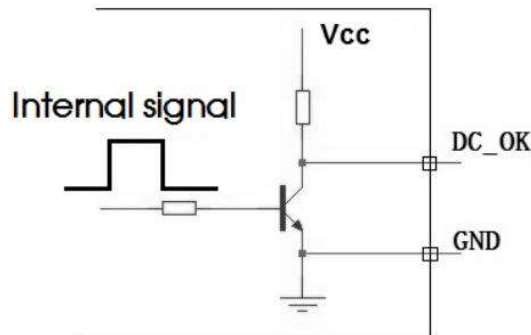
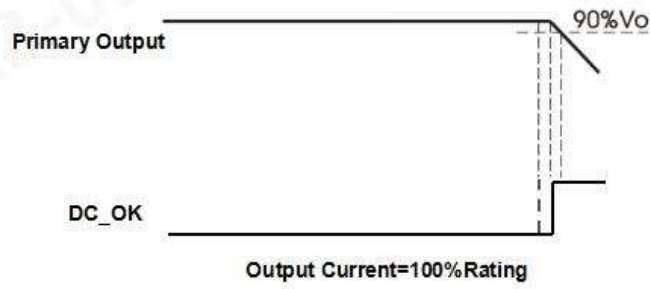

DC_OK (Pin7) and SGND (Pin13)	Output State
0 - 0.5V	Output on
10 - 12V	Output off

2.12 Remote compensation

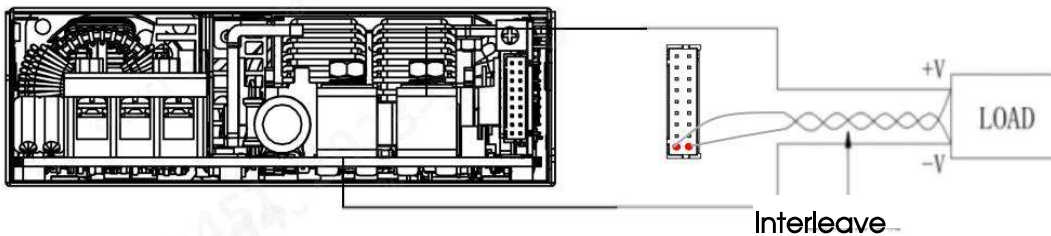

Note:

1. Vs+ and Vs- cannot be shorted or reversed, otherwise the power module will be damaged.
2. Before powering on the product, please confirm whether the control signal connection terminal (JP1300) Pin4 (PS_ON/OFF) and Pin13 (SGND) short-circuit jumper cap are connected. If not, the product without output. When the control signal connection terminal (JP1300) of the product are external

ZAMF-2000-Bxx Series

2000W, AC/DC 2000W Enclosed Switching Power Supply

connected as a whole, please ensure that Pin4 and Pin13 are short-circuit connected. Please refer to ZAMF-2000-Bxx Series Power Supply Application Notes: 2.10 Remote control.

3. Pin 9 and pin 18 of the signal terminal JP1300 can compensate the voltage drop on the output cable.

4. The remote compensation circuit can compensate 200mV cable voltage drop. This voltage includes the sum of the cable drop connected to the output positive terminal and the output negative terminal.

5. If remote compensation is to be used, this pin needs to be connected to the load using twisted pair cables.

2.13 Parallel operation

2.13.1 Redundancy

The power module output can be connected in parallel to achieve redundancy, thereby improving system reliability. The maximum power of the redundant system needs to be derated to ensure that the redundant system can still meet the rated load requirements when a power supply module fails. The current common practice is to construct a redundant system by the N+1 method, that is, N+1 power supplies are connected in parallel, to support the maximum load current $N \cdot I_{\text{omax}}$, where I_{omax} is the rated output current of each power supply. For example, the rated output current of each power supply is 40A, and 3+1 units are connected in parallel to construct a $3 \cdot 40\text{A} = 120\text{A}$ redundant system.

The power module supports 3+1 parallel redundant operation.

2.13.2 Current sharing

Method 1: Current sharing bus and remote compensation lines are both connected.

For load line loss $\leq 200\text{mV}$, and the output voltage difference of each single module $\leq 50\text{mV}$, this type of connection is recommended to obtain a better line-end output voltage and current sharing effect.

ZAMF-2000-Bxx Series

2000W, AC/DC 2000W Enclosed Switching Power Supply

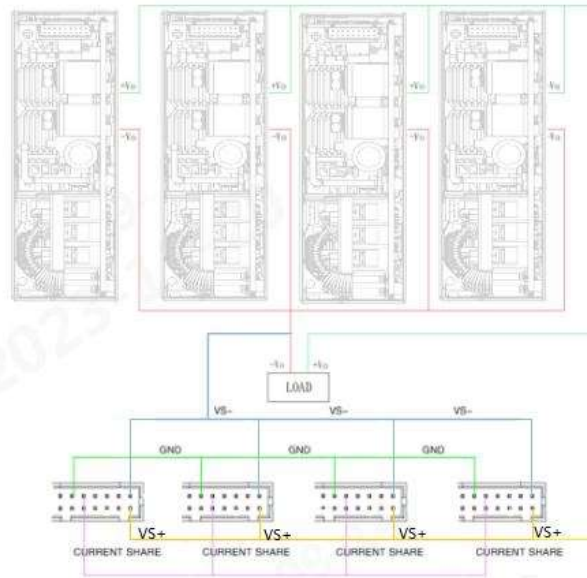

Method 2: Only the current sharing bus is connected, and the remote compensation is not connected.

For the load line loss $\geq 200\text{mV}$, or the output voltage difference of each single module cannot or does not need to be accurately adjusted to $\leq 50\text{mV}$, this type of connection is recommended to obtain a better current sharing effect of the parallel machine. In the same way, when the load loss is unknown or the current sharing fails to meet the specifications under the first connection method, it is recommended to replace it with this connected method. The wiring method of the current sharing function is shown in the figure below:

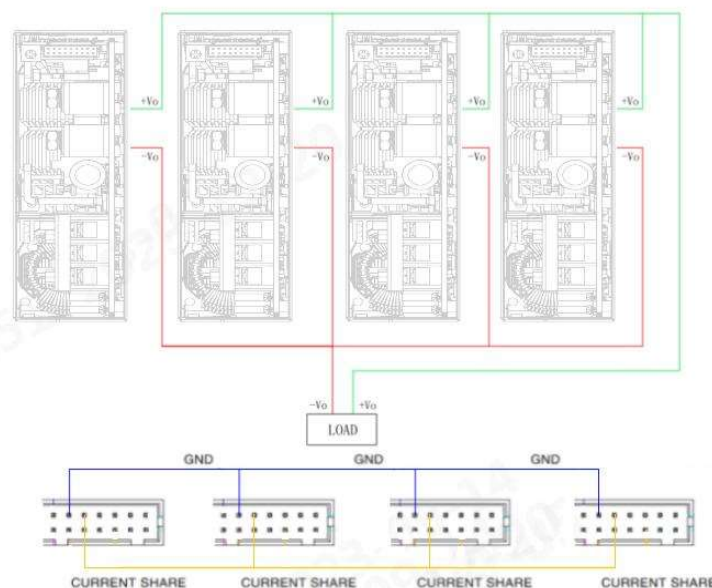

ZAMF-2000-Bxx Series

2000W, AC/DC 2000W Enclosed Switching Power Supply

Note: 1. When using in parallel, the number of parallel modules cannot exceed 4.

2. Before powering on the product, please confirm whether the control signal connection terminal (JP1300) Pin4 (PS_ON/OFF) and Pin13 (SGND) short-circuit jumper cap are connected. If not, the product without output. When the control signal connection terminal (JP1300) of the product are external connected as a whole, please ensure that Pin4 and Pin13 are short-circuit connected. Please refer to ZAMF-2000-Bxx Series Power Supply Application Notes: 2.10 Remote control.

When power modules work in parallel, there is an internal active current sharing circuit to ensure that the current between each module is balanced.

The active current sharing circuit adopts the automatic master-slave current sharing method. Each power module has a current sharing bus signal (CURRENT SHARE BUS). When working in parallel, the current sharing bus of all power modules must be connected together. The current-sharing bus signal is located at pin 14 of JP1300.

The output voltage of each power module will affect the current sharing accuracy. The output voltage of the power module is the rated voltage $\pm 50\text{mV}$. In practical applications, if the output voltage value needs to be adjusted, the output voltage of all parallel power supply modules needs to be adjusted to the same voltage. The recommended voltage range: target voltage value $\pm 50\text{mV}$

After the output load of each power module is greater than 50% of the rated load, the current sharing accuracy should be $\pm 10\%$. The current sharing calculation formula is:

$$\text{Current sharing accuracy} = \frac{I_{o \max} - I_{o \min}}{I_{o \max}} * 100\%$$

$I_{o \max}$: the maximum output current value in parallel power supply modules.

$I_{o \min}$: the minimum output current value in parallel power supply modules.

2.14 I2C communication address

In the parallel system, if you need to identify the power module information, you need to set the I2C communication address for each parallel power module, and exchange data with the host computer through I2C. The setting of the communication address is determined by pins 15, 16 and 17 of the signal terminal JP1300. When these three pins are short-circuited with pin 13 of JP1300, it will be low level (L, voltage range: 0 - 1.31V). When disconnected, it is high level (H, voltage range: 1.99V - 3.3V). The specific address number is shown in the table below:

ZAMF-2000-Bxx Series

2000W, AC/DC 2000W Enclosed Switching Power Supply

ADDRESS 2	ADDRESS 1	ADDRESS 0	Address number
L	L	L	0
L	L	H	1
L	H	L	2
L	H	H	3
H	L	L	4
H	L	H	5
H	H	L	6
H	H	H	7

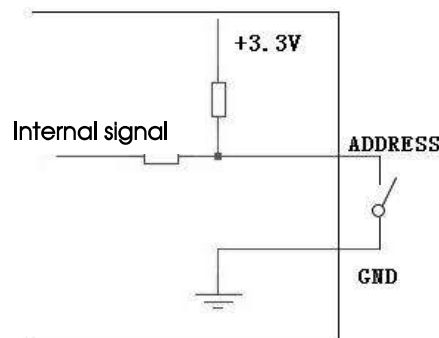

The internal pull-up resistance value of the power module is $10k\Omega$, and the external impedance can be matched according to the actual application to meet the high and low voltage range.

3. Installation requirements

3.1 Safety introduction

Warning: Risk of electric shock

During high voltage operating

- The power supply module is disconnected from the input DC or the AC power and placed for at least one minute before starting to operate it.
- When installing the input wire to the power module, please connect the ground terminal first, and then connect the L line and the N line.
- When removing the input wire, please remove the L wire and the N wire first, and then remove the ground wire.
- When disassembling, make sure that no objects fall into the power module.
- Pay attention to high temperature.
- After the power module is working in a high temperature environment, wait for its shell to cool down before operating.
- This product needs to be installed by professionals and needs to be used with other equipment.

ZAMF-2000-Bxx Series

2000W, AC/DC 2000W Enclosed Switching Power Supply

3.2 Safety requirements

When installing, pay attention to the primary side and the protective ground, the creep distance and the electrical clearance of the primary side and the secondary side refer to EN60601-1.

3.3 Installation method

Standard mounting orientation:

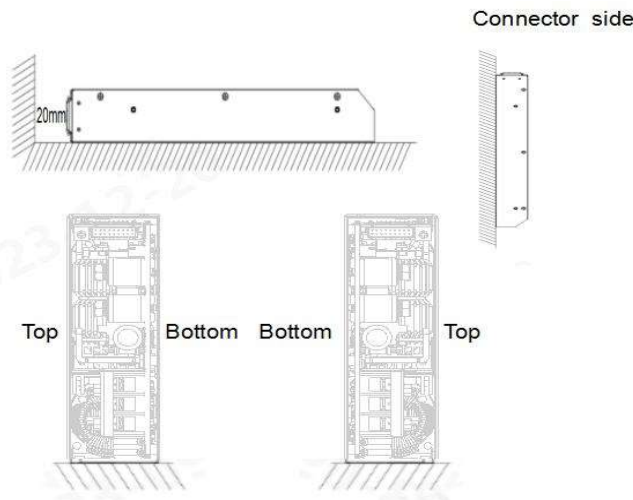

Position of mounting holes:

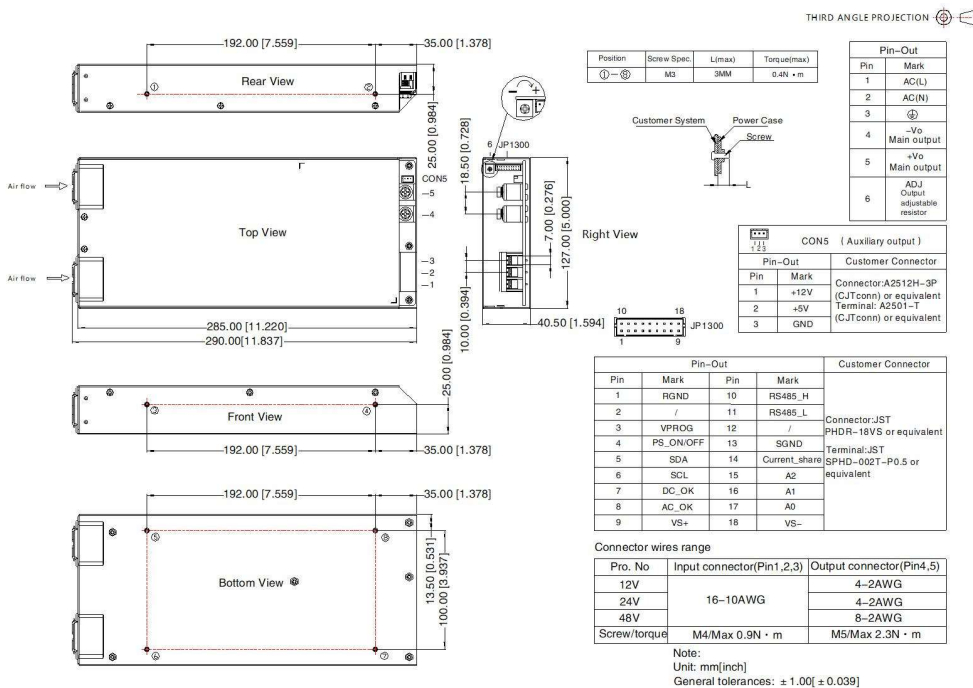

Note: The fan panel cannot be blocked by other objects, and a distance of at least 20mm must be maintained, otherwise it will affect the heat dissipation and performance of the power module.

ZAMF-2000-Bxx Series

2000W, AC/DC 2000W Enclosed Switching Power Supply

4.Communication protocol

The ZAMF-2000-Bxx series power modules support standard 485 communication protocols and monitor the power modules through I2C bus.

4.1 Hardware parameter

The baud rate is 38400Baud/S. Byte format: 1start bit, 8data bit, 1 stop bit, no parity bit.

4.2 Data frame format

The format of the data communication frame is based on the Modbus-RTU mode standard, and only block read commands are supported. The format of the data frame sent and received is as follows:

Upper computer TX	Byte0	Byte1	Byte2	Byte3	Byte4	Byte5	Byte6	Byte7
	Addr	Fun_Code	RegAdd_H	RegAdd_L	Num_H	Num_L	CRC_L	CRC_H
Slave computer RX	Byte0	Byte1	Byte2	Byte3	Byte4	...	ByteN	ByteN+1
	Addr	Fun_Code	ByteNum	Uint16_H	Uint16_L	...	CRC_L	CRC_H

The IP address of the lower computer is 0x00 - 0x07, where 0x00 is the broadcast address, and only the block read command 0x03 is supported. In double-byte data, the high byte is in front of the low byte and the low byte is in front of the CRC check code.

ZAMF-2000-Bxx Series

2000W, AC/DC 2000W Enclosed Switching Power Supply

4.3 Register data definition

Category	Register address	Data name	Data type	Read and write permission	Bytes of variable	Data specification
Factory information	0x0000	Bar code	String	R	32	
	0x0010	Model number	String	R	32	ZAMF-2000-Bxx
	0x0020	Software version	String	R	32	V1.0
	0x0030	Software date	String	R	32	Software date
	0x0040	yieldly	String	R	32	
	0x0050	series	String	R	32	ZAMF- enclosed power supply
Analog quantity	0x0060	Output voltage	Uint16	R	2	0.01V/LSB
	0x0061	Output current	Uint16	R	2	0.01A/LSB
	0x0062	Output power	Uint16	R	2	0.1W/LSB
	0x0063	(reserve)	Uint16	R	2	
	0x0064	(reserve)	Uint16	R	2	
	0x0065	temperature	Uint16	R	2	0.01 °C/LSB offset -40 °C
	0x0066	System fault code	Uint16	R	2	Definitions are given in the table below
	0x0067	System status code	Uint16	R	2	Definitions are given in the table below

Fault code definition			
Bit0	Fan 1 is faulty	Bit8	The secondary overload of the main route is faulty
Bit1	Fan 2 is faulty	Bit9	The third overload of the main route is faulty
Bit2	(reserve)	Bit10	The rear stage over-temperature is faulty. Procedure

ZAMF-2000-Bxx Series

2000W, AC/DC 2000W Enclosed Switching Power Supply

Bit3	The main route over-voltage is faulty	Bit11	The main route short-circuit is faulty
Bit4	(reserve)	Bit12	The main hardware over-voltage
Bit5	The main route over-current is faulty	Bit13	The front hardware is overheated. Procedure
Bit6	(reserve)	Bit14	Constant current fault
Bit7	The primary overload of the main route is faulty	Bit15	(reserve)

Status code definition			
Bit0	External power-on flag bit	Bit8	Fault flag bit
Bit1	Enter the AC power-on flag	Bit9	(reserve)
Bit2	PFC output flag bit	Bit10	(reserve)
Bit3	BUS voltage OK flag bit	Bit11	(reserve)
Bit4	DC output flag bit	Bit12	AC voltage detection flag bit
Bit5	DC output ready flag bit	Bit13	Fan running flag bit
Bit6	(reserve)	Bit14	Relay flag bit
Bit7	Peak power flag bit	Bit15	System initialization flag bit